

SHARP®

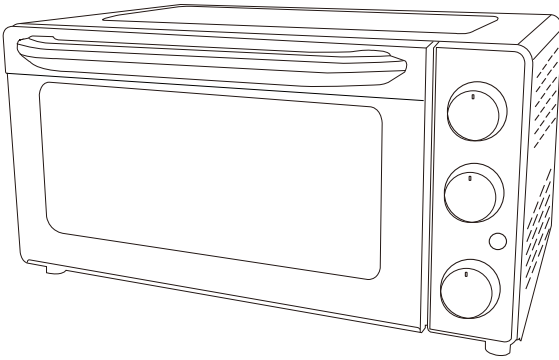

ELECTRIC OVEN

EO-187-BK
EO-187-ST
EO-187T-BK
EO-187T-ST
EO-B18V-BK

Please read these instruction carefully before operating the appliance.

OPERATION MANUAL

CONTENTS

	<u>Page</u>
Safety Precautions	3-7
Product Components & Specifications	8
Operating Instructions	9-12
Cleaning and Maintenance	13
Troubleshooting	14

SAFETY PRECAUTIONS

Please follow this instruction manual strictly to operate this unit correctly.

To avoid any personal injury and property loss, please comply with the following safety notices. Accidents may occur if the user does not comply with the safety notices and operates the unit incorrectly.

- Ignorance or wrong understanding of those marks below will cause two circumstances.

 **Warning** : It may cause severe injuries.

 **Caution** : It may cause personal injury or damage to other objects.

- The seriousness is classified by the following indicators.



This symbol indicates never to do this.



This symbol indicates always to do this.

BEFORE THE FIRST USE:

Remove and unpack all packing materials. Check that all parts and components are complete and not damaged. If any part of the appliance is found to be damaged, it must be brought to appointed SHARP service center to be checked, repaired or replaced to prevent any hazards occurring.



Please do not dismantle or repair the appliance by yourself for safety purposes.

Clean the unit according to the “Cleaning and Maintenance” section before using.

This appliance is only applicable for household usage. Please operate the unit according to the operation manual, and do not misuse the appliance for purposes other than its actual function.



If the power cord is damaged, the appliance must be brought to appointed SHARP service center for repair or replacement to prevent any hazards occurring.

- Do not damage or alter the power cord arbitrarily. It should not be twisted, extended, bundled up or placed near hot places. Do not place heavy objects on the power cord or place the cord in the gap between objects.
- Do not let the power cord hang over the edge of table or countertop. Do not place the power cord on hot surfaces.
- If the power cord or power plug is damaged or failed to function normally, (e.g. being expanded, deformed, changed in color, part of the power cord is hotter than usual, power cord is loosened in the socket, or power is on and off from time to time), please stop using it. Send it to a SHARP service center for repair services.



Use a wall grounded socket individually (>10A, AC 220-240V ~ 50/60Hz); please ensure that the output voltage of the grounded socket matches the appliance.

- Using socket with low rate current or sharing the socket with other appliances may cause partial overheating and may lead to fire hazard or electrical shock.
- A voltage stabilizer can be used to avoid damages.
- Please ensure the power plug is fully secured into the socket before switching on the power.



When the appliance is not in use or undergoing maintenance, please turn off the power supply and remove the plug from socket.

- Please hold onto the plug firmly when removing it from power socket and prohibit pulling the power cord.
- Do not touch the power plug with wet hands to avoid electrical shock.
- If there is dust or dirt on the power plug, please wipe them away with a dry cloth, otherwise it may lead to fire hazard. Never use a wet cloth or water to clean the power plug.



Do not disassemble or repair the appliance or replace any components by yourself. Only components supplied by SHARP can be used.



- For repair services, please contact SHARP service center to avoid electric shock, short circuit, fire hazard, etc.
-

If the appliance happens to be dropped or is broken, stop using it and please send it to the SHARP service center for repair services



- Otherwise, it may result in electric shock or even fire hazard.
 - If the appliance is dropped into the water, do not reach for it. Switch off all power sources, drain the water away then only retrieve the appliance to be sent for repairs.
-

Keep the appliance away from water and fire, and do not use the appliance on an inclined or unstable platform, to avoid from any accidents or damages.



- Do not use the appliance on inflammable objects like paper, cloth, carpet or plastic bags.
 - Do not use the appliance on uneven places.
 - When using the appliance, do not place appliance near the wall or furniture or under the sunlight, or places where it may be splashed by oil.
-

The appliance must not be immersed into the water.



- The appliance will be damaged, and it may cause short circuit or electric shock.
-

If the oven is positioned close to a wall, the wall will have burn or stain marks.



- Please ensure that hanging fabrics are not placed nearby or in contact with the oven body.
-

Do not put anything between the bottom of oven and the surface it is set on.



- Any object so placed could be burned or deformed.
-

Do not put anything on the oven during operation.



- The heat could cause deformation, cracking, etc.
-

Please operate the appliance correctly according to the operating instructions.



- Avoid fire hazard or electric shock caused by improper operation, such as liquid overflowing to the connector between power cord and cooker.
-

Any bottled or canned food must not be heated directly.



- The bottle or tin can would explode and cause severe damages and injuries.
-

Do not place foil wrapped food into the oven.



- Remove all protective wrapping prior to placing food in the oven.
-

During operation, do not move the appliance and do not get too close to the appliance or touch any hot part of the appliance.



- Please keep face and hands away from the appliance to avoid scalding.
 - The temperature of the accessible surface may be high when the appliance is operating.
 - Immediately after using the oven, please be careful as the metal parts and glass window of the door would be extremely hot.
-

Always use the tray handle when inserting or removing the tray.



- Touching the hot tray/rack will cause severe burns.
-

When the appliance is hot, do not apply any water to the glass window.



- It may cause the glass to break and may result in personal injury.
-

Please turn off the power supply before remove the baking tray.



Do not start cleaning until the appliance is cooled down.



- Avoid touching any hot part of the appliance or it may cause scalds.
-

Clean the appliance each time after using.



- Do not use steel scrubs, abrasive cleansers or corrosive liquid (e.g. Gas or Acetone) to clean the appliance.
-

Be sure to switch off the appliance after operating to ensure safety.



- Ensure that the power switch is off in order to avoid any unforeseen accidents.
-

The appliance is not intended to be operated by means of an external timer or separate remote control system.



The surface is liable to get hot during use.



This appliance is not intended for use by persons (including children) with reduced physical, sensory or mental capabilities, or lack of experience and/or knowledge, unless they have been given supervision or instruction in the safe use of the appliance and have understood the potential risk.



Children should be supervised to ensure that they do not play with the appliance.



PRODUCT COMPONENTS

1. Door handle
2. Main body
3. Temperature knob
4. Function knob
5. Timer knob
6. Crumb tray
7. Baking rack
8. Baking tray
9. Tray handle
10. Indicator light

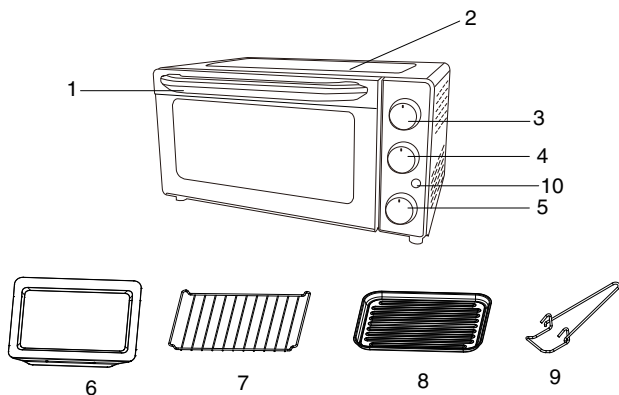

PRODUCT SPECIFICATIONS

Rating Voltage	220-240V~
Rating Frequency	50/60Hz
Rating Power	1300W
Capacity	18L
Product Dimension (W x D x H)	432 x 383 x 231mm
Accessories	Crumb tray (x1) Baking rack (x1) Baking tray (x1) Tray handle (x1)

OPERATING INSTRUCTIONS

Before using the appliance, please refer to “Cleaning and Maintenance” in order to clean the components properly.

Before operating the appliance, ensure that there is at least 10cm distance of space on the front and both sides of the oven for adequate air circulation. Please ensure the crumb tray is properly installed before using.

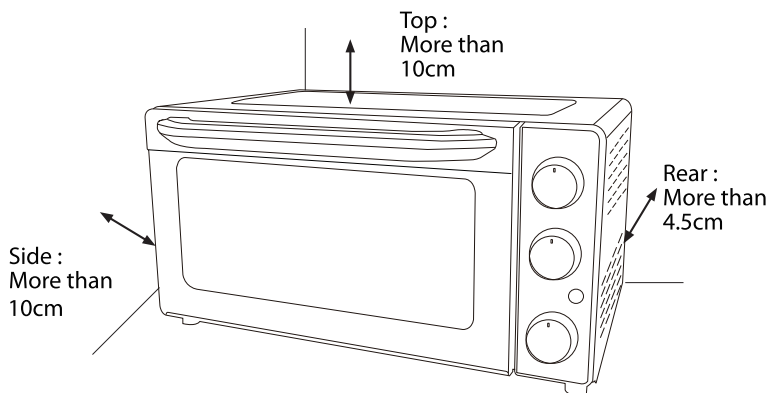

For the first time of usage, set the temperature knob to the MAX, with function setting on  , and the timer to 15 minutes. This will help to burn off any oil which are still remained in the oven.



NOTE: The oven may emit smoke during this process. This is normal for a new oven and will not last for more than 10-15 minutes.

CONTROL SETTINGS

Function Settings

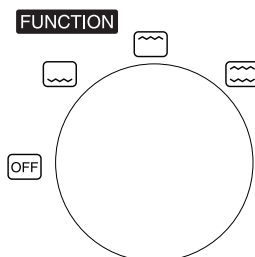
This electric oven offers 3 different functions for versatile cooking all in one appliance.



	The lower heating elements will be heating up during this function.
	The upper heating element will be heating up during this function.
	Both the upper and lower heating elements will be heating up during this function.

TEMPERATURE SETTINGS

- Turn the “Temperature” knob clockwise to the desired temperature setting. The temperature can be set from 70°C to 230°C.

TIMER SETTINGS

- The timer can be set up to 120 minutes.
- The oven will not begin operation if the timer has not been set. To set the timer, turn the “Timer” knob clockwise to the desired time.
- The light indicator will be lit up only when the timer has been set.
- When the timer has reached the “OFF” position, a bell sound will be heard to indicate completion of operation. The power supply will be cut off automatically until the timer is being set again.

ADJUSTING TIMER SETTINGS

- The timer can be changed and adjusted even during the cooking period. Just turn the timer knob to the newly desired time and let the oven continue cooking.
- **NOTE:** When setting the “Timer” knob to 5 minutes or less, always rotate the timer to over 20 minutes first, then only rotate it back to the user’s chosen time. This will ensure a safe and accurate timer setting.

“STAY ON” FUNCTION

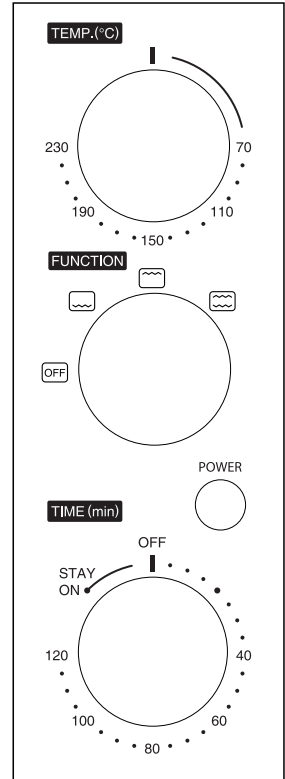

- To use the oven without any timer setting, turn the “Timer” knob to “STAY ON” position. Then turn “Temperature” knob to desired setting.
- In this case, the oven will operate until the user decides to stop the operation by turning the knob to the “OFF” position.
- **NOTE:** Close supervision is necessary when using “STAY ON” function. It is applicable to all functions.



BEFORE OPERATING THE APPLIANCE

1. Please ensure that an oven-proof container is being used in the oven. Do not use a plastic or cardboard container in the oven.
2. Do not use glass or ceramic type of pan and lid.
3. For easy cleaning, please use the crumb tray at all times when cooking.
4. Before cooking, please set the temperature as suggested by the recipes.
5. Please ensure the oven door is securely close at all times before and during the cooking of the food in the oven.

TO OPERATE THE APPLIANCE AND COOK THE FOOD

1. Place the baking rack in a position that will accommodate the height of the food to be cooked.
2. Set the food on the baking rack.
3. Set the “Function” knob towards desired function ( ,  , and ).
4. Rotate the “Temperature” knob towards desired cooking temperature.
5. Rotate the “Timer” knob towards desired cooking time.
6. The oven will begin operating for the desired length of cooking time under the desired function and cooking temperature.
7. When the cooking is finished, a bell sound will be heard.
8. Check the temperature of the cooked food to ensure that the proper internal temperature of the food have been reached to avoid having food that are not fully cooked.
9. Always use the tray handle when inserting or removing the tray. Touching the hot tray/ rack will cause severe burns.

NOTE: Bake with only one tray at a time for more ideal baking result.

CLEANING AND MAINTENANCE

1. Please wait for the appliance to fully cool down before washing and cleaning.
2. Please ensure the switch and power supply is off before cleaning the appliance.
3. Please clean the appliance promptly after using.
4. Do not clean the main unit with water directly; use only damp cloth or soft sponge to wipe the surface and interior of the appliance.
5. To clean the door, use a damp cloth saturated with detergent or soap to wipe it, then use a clean and dry cloth to wipe it dry.
6. Wash all attachments including the rack and baking tray with mild, soapy water.
7. Do not use abrasive cleaners, scrubbing brushes and chemical cleaners as this will cause damages to the coating of the baking tray.
8. Please keep the appliance dry and avoid it being exposed to the sun when storing it.
9. Before storing, please ensure that the appliance is completely clean and dry.

Important Notices:

1. Surfaces that are always in contact with food should be cleaned regularly to avoid cross contamination from different types of food.
2. The use of hot clean water with a mild detergent is advisable when dealing with these kind of surfaces that will be in regular contact with food.
3. Correct food hygiene practices should always be followed at all times to avoid the possibility of any food poisoning or even cross contamination.

TROUBLESHOOTING

Malfunction Phenomenon	Possible Causes	Troubleshooting Method
Oven will not turn on.	The oven is not plugged in securely.	Remove the plug from outlet, wait for 10 seconds then reinsert the plug.
	The circuit breaker or fuse in your home is tripped.	Reset the circuit breaker or replace the fuse in your home.
	There is a problem with the power outlet.	Insert a different appliance's power plug into the outlet to check if the outlet is working.
Oven smokes excessively during cooking.	A wrong cooking function may have been selected.	Check if you have selected the correct cooking function for the dish.
	Wrong accessories/ cookware may have been used for selected cooking function.	Check if you have used the correct accessories/ cookware.
	Wrong cooking temperature may have been selected.	Check if the temperature selected is correct.
	Food deposits sticking onto the enamel coating inside the oven becomes charred and creates both smoke and unpleasant odors.	Regular cleaning is necessary to remove grease build-up.
	Grease or food spatters can also cause excessive smoking	Regular cleaning is necessary to remove grease build-up.
Food is not being cooked properly.	A wrong cooking function may have been selected.	Check if you have selected the correct cooking function for the dish.
	Wrong cooking temperature may have been selected.	Check if the temperature selected is correct.
	Rack position may be incorrect for the cooking function selected.	Check if the tray is placed at the recommended height.
	Wrong accessories/ cookware may have been used for selected cooking function.	Check if you have used the correct accessories/ cookware.

Notice: Above listed are common malfunctions and troubleshooting methods. Regarding other types of malfunction, please contact SHARP service center for repair services.

ENVIRONMENT FRIENDLY DISPOSAL



You can help protect the environment!

Please remember to respect the local regulations: hand in the non-working electrical equipment to an appropriate waste disposal center.

SHARP

SHARP CORPORATION