

聲寶牌 **SHARP** 夏普

**AX-1700R**

香港電器安全規格  
(國際電工委員會規格適合)

**HEALSIO**

**水波爐**  
**WATER OVEN**

**使用說明書**  
**OPERATION MANUAL**



## 目錄

	頁數		頁數
重要安全須知.....	C-1	其它簡便功能指南.....	C-20
安裝事宜.....	C-3	清洗及注意事項.....	C-22
各部位名稱.....	C-4	故障查閱指南表.....	C-24
控制板.....	C-5	維修前檢查.....	C-27
重要須知.....	C-6	規格.....	C-27
操作之前.....	C-9	烹調指南.....	C-28
首次使用之前請清潔烤爐.....	C-9	自動烹調食譜.....	C-31
自動烹調.....	C-10		
自選烹調.....	C-14		

## CONTENTS

	Page		Page
IMPORTANT SAFETY INSTRUCTIONS.....	E-1	OTHER CONVENIENT FEATURES.....	E-20
INSTALLATION INSTRUCTIONS.....	E-3	CLEANING AND CARE.....	E-22
OVEN DIAGRAM.....	E-4	TROUBLESHOOTING CHART.....	E-24
CONTROL PANEL.....	E-5	SERVICE CALL CHECK.....	E-27
IMPORTANT INSTRUCTIONS.....	E-6	SPECIFICATIONS.....	E-27
BEFORE OPERATING.....	E-9	COOKING GUIDES.....	E-28
CLEAN THE OVEN BEFORE FIRST USE.....	E-9	AUTOMATIC COOKING CHART.....	E-31
AUTOMATIC COOKING.....	E-10		
MANUAL COOKING.....	E-14		

# IMPORTANT SAFETY INSTRUCTIONS

## IMPORTANT SAFETY INSTRUCTIONS: READ CAREFULLY AND KEEP FOR FUTURE REFERENCE

1. This oven is designed to be used on a countertop only. It is not designed to be built-in to a wall or cabinet. Do not place the oven in a cabinet. See page E-3 for the installation.  
The oven door may become hot during cooking. Place or mount the oven so that the bottom of the oven is 85 cm or more above the floor. Keep children away from the door to prevent them from burning themselves.
2. Ensure there is a minimum of free space above the oven of 13 cm.
3. This appliance is intended to be used in household and similar applications such as:
  - staff kitchen areas in shops, offices and other working environments;
  - farm houses;
  - by clients in hotels, motels and other residential environments;
  - bed and breakfast type environments
4. The microwave oven is intended for heating food and beverages.  
Drying of food or clothing and heating of warming pads, therapeutic devices (eg. wheat bags), slippers, sponges, damp cloth and similar may lead to risk of injury, ignition or fire.
5. This appliance is not intended for use by persons (including children) with reduced physical, sensory or mental capabilities, or lack of experience and knowledge, unless they have been given supervision or instruction concerning use of the appliance by a person responsible for their safety.
6. Children should be supervised to ensure that they do not play with the appliance.
7. **WARNING:** Only allow children to use the oven without supervision when adequate instructions have been given so that the child is able to use the oven in a safe way and understands the hazards of improper use.
8. **WARNING:** When the appliance is operated in Convection, Grill or Steam functions, children should only use the oven under adult supervision due to the temperature generated.
9. **WARNING:** Accessible parts may become hot during use. Young children should be kept away.
10. **WARNING:** If the door or door seals are damaged, the oven must not be operated until it has been repaired by a qualified service technician trained by SHARP.
11. **WARNING:** Never adjust, repair or modify the oven by yourself. It is hazardous for anyone other than a qualified service technician trained by SHARP to carry out any service or repair operation that involves the removal of a cover which gives protection against exposure to microwave energy.
12. If the power supply cord of this appliance is damaged, it must be replaced by a qualified service technician trained by SHARP in order to avoid a hazard.
13. **WARNING:** Liquids and other foods must not be heated in sealed containers since they are liable to explode.
14. Microwave heating of beverages can result in delayed eruptive boiling, therefore care must be taken when handling the container.
15. Eggs in their shell and whole hard-boiled eggs should not be heated on microwave modes since they may explode, even after microwave heating has ended. To cook or reheat eggs which have not been scrambled or mixed on microwave modes, pierce the yolks and the whites, or the eggs may explode. Shell and slice hard boiled eggs before reheating them on microwave modes.
16. Utensils should be checked to ensure that they are suitable for use in the oven. See Page E-29. Use only microwave safe containers and utensils on microwave modes.
17. Metallic containers for food and beverages are not allowed during microwave modes.
18. The contents of feeding bottles and baby food jars shall be stirred or shaken and the temperature checked before consumption, in order to avoid burns.
19. During use the appliance becomes hot. Care should be taken to avoid touching the heating elements and oven cavity. To prevent burns, always use thick oven gloves. Before cleaning make sure they are not hot.
20. When heating food in plastic or paper containers, keep an eye on the oven due to the possibility of ignition.
21. If smoke is observed, switch off or unplug the appliance and keep the door closed in order to stifle any flames.
22. The oven should be cleaned regularly and any food deposits removed.
23. Cleaning and user maintenance shall not be performed by children without supervision.
24. Failure to maintain the oven in a clean condition could lead to deterioration of the surface that could adversely affect the life of the appliance and possibly result in a hazardous situation.
25. Do not use harsh abrasive cleaners or sharp metal scrapers to clean the oven door glass since they can scratch the surface, which may result in shattering of the glass.
26. Steam cleaner is not to be used.
27. See instructions for cleaning door seals, cavities and adjacent parts on page E-22.
28. See instructions for using accessories on page E-4.

### Other warnings

1. To reduce the risk of fire in the oven cavity:
  - a. No other liquid than room temperature water suitable for drinking (filtered) can be poured into the water tank.
  - b. The oven should not be left unattended during operation. High oven temperature or long cooking time may overheat foods resulting in a fire.
  - c. Do not overcook food.
  - d. Remove wire twist-ties from paper or plastic bags before placing bag in the oven.
  - e. Do not heat oil or fat for deep frying. The temperature of the oil cannot be controlled.
  - f. Do not use containers made of synthetic material for cooking. They could melt at high temperature.

# IMPORTANT SAFETY INSTRUCTIONS

- g. Do not use plastic containers if the oven is still hot because they may melt. Plastic containers must not be used unless the container manufacturer claims it is suitable.
  - h. Do not store food or any other items inside the oven.
  - i. When alcoholic beverages are added when roasting or cooking cakes and sweets, there is a risk that vapours released by the alcohol may catch fire upon coming into contact with the electrical heating element. Attend the oven closely during cooking.
2. To reduce the risk of an explosion or delayed eruptive boiling, care should be taken when handling the container. Your oven is capable of heating food and beverages very quickly with microwave, therefore it is very important that you select the appropriate cooking time and power level for the type and quantity of food to be heated. If you are unsure of the cooking time and power level required, begin with low cooking times and power levels until the food is sufficiently heated evenly throughout.  
Additionally:
  - a. Do not place sealed containers in the oven. Babies bottles fitted with a screw cap or teat are considered to be sealed containers.
  - b. Do not use excessive amount of time.
  - c. When boiling liquids in the oven, use a wide-mouthed container.
  - d. Stand at least for 20 seconds at the end of cooking to avoid delayed eruptive boiling of liquids.
  - e. Stir the liquid before and during cooking. Use extreme care when handling the container or inserting a spoon or other utensil into the container.
3. This oven is for home food preparation only and should only be used for heating, cooking and defrosting food and beverage.  
It is not suitable for commercial, laboratory use, or heating therapeutic devices eg. Wheat bags.
4. Never operate the oven whilst any object is caught or jammed between the door and the oven.
5. Handle with care when removing items from the oven so that the utensil, your clothes or accessories do not touch the latches.
6. Never poke an object, particularly a metal object, through a grille or between the door and the oven while the oven is operating.
7. Never tamper with or deactivate the latches.
8. Always use thick oven gloves to prevent burns when handling utensils that are in contact with hot food. Enough heat from the food can transfer through utensils to cause skin burns.
9. If the oven lamp fails please consult your dealer or a qualified service technician trained by SHARP.
10. Avoid steam burns by directing steam away from the face and hands. Slowly lift the furthest edge of a dish's cover including microwave plastic wrap etc., and carefully open popcorn and oven cooking bags away from the face.
11. Make sure that the power supply cord is undamaged, and that it does not run under the oven or over any hot surfaces or sharp edges.
12. Use care when opening door. To avoid burns from escaping heat and steam, let hot air or steam escape before removing or replacing food.
13. Do not place anything on the outer cabinet because the oven will become very hot during operation.
14. To avoid burns, always test the food and container temperature and stir before serving. Pay special attention to the temperature of food and drink given to babies, children and the elderly. Do not drink beverages or soup without checking the container's temperature. Take extra caution when handling the container because it becomes very hot.
15. Make sure the utensil does not touch the interior walls during cooking.
16. Do not touch the oven door, outer cabinet, rear cabinet, oven cavity, air-vent openings, accessories and dishes because the escaping steam from the ventilation cover during operation becomes hot.
17. Do not touch around the oven lamps directly. This part will become hot when the oven lamp is on.
18. When the oven is in use, ventilate a room where the oven is installed. e.g. open a window or switch a kitchen ventilation fan on. Steam from the ventilation cover may wet nearby wall or furniture.
19. Do not operate the oven if the water tank cracks and water leaks. Please contact a SERVICE CENTRE APPROVED BY SHARP.
20. Do not insert fingers or objects in the holes (the steam outlets or air-vent openings) as this may damage the oven and cause an electric shock or a hazard.
21. Do not touch the electric plug with wet hand. Plug into the electric wall socket securely. When removing the plug from the socket always grip the plug, never pull the power supply cord as this may damage the power supply cord and the connections inside the plug.
22. Never move the oven when it is operating. If the oven needs to be moved, always drain all water inside the oven using DRAIN WATER. After draining, empty the drip tray.
23. Do not put any water on the door or control panel intentionally.
24. If the oven falls down or drops on the floor, do not use the oven. Unplug the unit and contact a SERVICE CENTRE APPROVED BY SHARP.
25. Do not place any things weighing more than 4 kg on the door to prevent that the oven may fall down or could damage the door and hinges. Do not cling onto the handle and do not hang heavy objects from it.
26. To prevent condensation which could corrode the appliance, do not leave cooked food in the oven for an extended period.

# INSTALLATION INSTRUCTIONS

1. Remove all packing materials from the oven cavity, and the feature sticker from the outside of the door, if there is one. Check the unit for any damage, such as a misaligned door, damaged door seals around the door or dents inside the oven cavity or on the door. If there is any damage, please do not operate the oven until it has been checked by a SERVICE CENTRE APPROVED BY SHARP and repaired, if necessary.
2. Accessories provided  
1) Rack 2) 2 Baking trays 3) Operation manual
3. Since the door may become hot during cooking, and in order to avoid its accidental touch, the oven should be placed at least 85 cm or more above floor. You should also keep children away from the door to prevent them burning themselves.
4. This oven is designed to be used on a countertop only. It should not be installed in any area where excessive heat and steam are generated, for example, next to a conventional oven unit. It should not be installed near combustible materials, for example, curtains. The oven should be installed so as not to block ventilation openings. A fire may occur if this appliance is covered or touching flammable material, including curtains, drapes, walls, etc. Allow space of at least 13cm from top of the oven for air ventilation. This oven is not designed to be built-in to a wall or cabinet.  
**WARNING: Steam is ventilated from the top rear of the oven. Make sure the escaping steam does not wet electrical outlets/other electrical appliances.**
5. If the window is close to the oven, keep more than 20 cm distance between the ventilation and the window. Window may be broken by the heat from the ventilation.  
**CAUTION: Steam ventilated from the oven may wet or dirty nearby furniture or wall. Keep sufficient space between the oven and the wall or furniture. Steam comes from the ventilation cover or door during cooking or after cooking. Steam may be condensed on the wall or furniture around the oven. Install the oven where it can be well ventilated.**  
**To prevent from wet, we recommend to cover the wall or furniture with aluminium foil.**
6. Do not connect other appliances to the same socket using an adaptor plug.
7. Neither the manufacturer nor the distributors can accept any liability for damage to the machine or personal injury for failure to observe the correct electrical connecting procedure. The A.C. voltage and frequency must correspond to the one indicated on the rating label.
8. This appliance must be earthed:

## IMPORTANT

The wires in power supply cord are coloured in accordance with the following code:

Green-and-yellow	:	Earth
Blue	:	Neutral
Brown	:	Live

As the colours of the wires in the power supply cord of this appliance may not correspond with the coloured marking identifying the terminals in your plug, proceed as follows:

The wire which is coloured green-and-yellow must be connected to the terminal in the plug which is marked with the letter E or by the earth symbol  $\perp$  or coloured green or green-and-yellow.

The wire which is coloured blue must be connected to the terminal which is marked with the letter N or coloured blue.

The wire which is coloured brown must be connected to the terminal which is marked with the letter L or coloured brown.

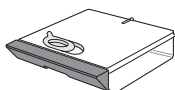

When unpacking your Water Oven, you may notice a small amount of water inside the oven and water tank.

This is a normal phenomenon of testing.

# OVEN DIAGRAM

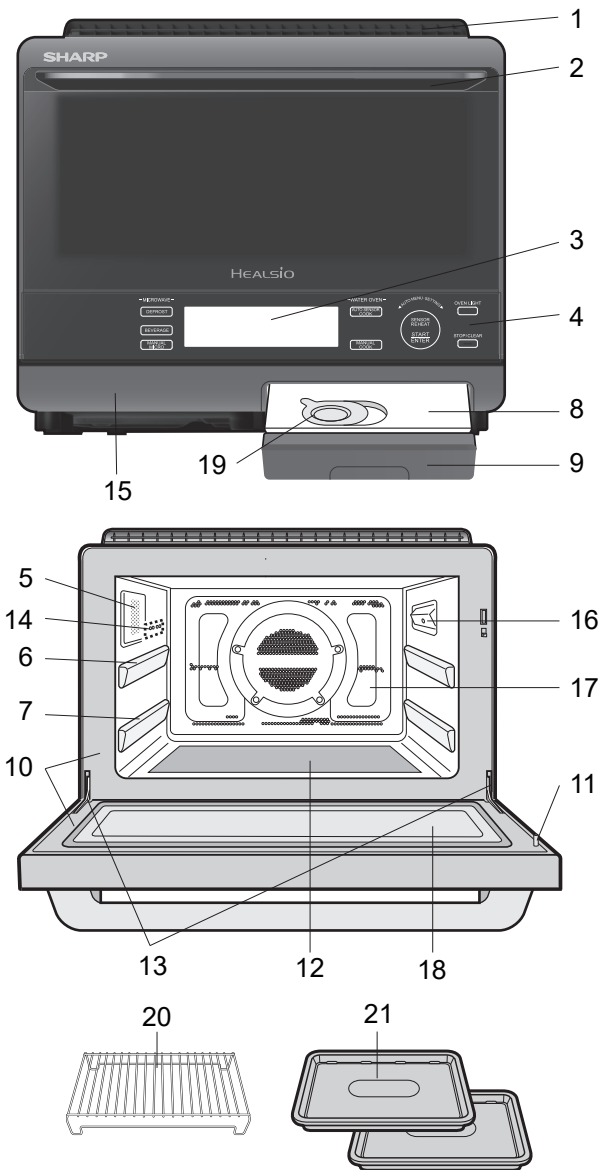

- 1** Ventilation openings
- 2** Door open handle
- 3** LCD display
- 4** Control panel
- 5** Oven lamp
- 6** Shelf runner (upper position)
- 7** Shelf runner (lower position)
- 8** Water tank lid (See page E-6.)
- 9** Water tank (See page E-6.)
- 10** Door seals and sealing surfaces
- 11** Latches
- 12** Ceramic oven floor
- 13** Door hinges
- 14** Steam outlets
- 15** Drip tray (See page E-6.)
- 16** Infrared sensor
- 17** Oven cavity
- 18** See through door
- 19** Flip-up lid

## ACCESSORIES

- 20** Rack  
For Convection, Grill or Steam function.  
Do not use when microwave cooking.  
Always place on baking tray.
- 21** Baking tray x2  
For Convection, Grill or Steam function.  
Do not use when microwave cooking.

## WARNING:

**The oven cavity, door, outer cabinet, accessories and dishes will become very hot, use thick dry oven gloves when removing the food or accessories from the oven to prevent burns.**

## OPTION NUMBER

The following options are selected by turning the Knob. Each option number will be shown in the display.

### AUTO MENU

- 1 Crispy Reheat
- 2 Steam Reheat
- 3 Reheat Bread
- 4 Reheat Frozen Food
- 5 Reheat as Temperature
- 6 Grilled Chicken
- 7 Deep Fried Chicken
- 8 Grilled Fish
- 9 Steamed Vegetables
- 10 Baked Sweet Potato
- 11 Toast
- 12 Breakfast Set
- 13 Sponge Cake
- 14 Cream Puff
- 15 Dried Food

### MANUAL COOKING

- 16 Grill
- 17 Steam High
- 18 Steam Low
- 19 Steam Proof
- 20 Proof

### MAINTENANCE

- 21 Sterilization
- 22 Drain Water
- 23 Steam Clean
- 24 Descale
- 25 Clean Oven  
(First Use)

# CONTROL PANEL

## Operating Pads

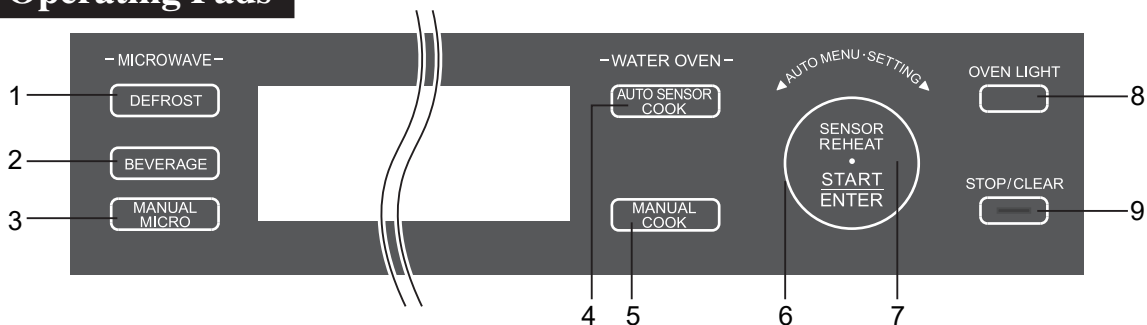

### 1. DEFROST pad

Press to defrost food. DEFROST has 2 options; "Defrost" and "Defrost Low"

### 2. BEVERAGE pad

Press to reheat beverage.

### 3. MANUAL MICRO pad

Press to select Manual Microwave cooking.

### 4. AUTO SENSOR COOK pad

Press to select Auto Sensor Cook (ALL IN ONE)

### 5. MANUAL COOK pad

Press to select Manual Convection cooking.

### 6. Knob

Turn to select desired option.

### 7. SENSOR REHEAT / START / ENTER pad

Press to reheat food automatically.

Press to start oven after setting programmes.

Press to confirm your choice.

\* The indicator light will flash to remind you to press the pad or turn the knob.

### 8. OVEN LIGHT pad

Press to light the oven lamp during the cooking for 10 seconds.

### 9. STOP / CLEAR pad

Press to clear during programming.

Press to cancel cooking programme.

## Display Information

The display shows useful information including cooking time and cooking mode.

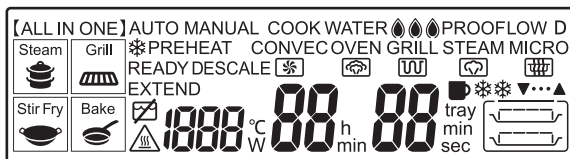

### OVEN CONDITION INDICATORS:

: The oven is very hot.

: Check the water tank.

READY : Preheat is complete.

DESCALE : Descaling is necessary.

D : Demo mode is in progress.

COOK : The oven is in operation.

EXTEND : You can extend cooking time.

: Superheated steam level indicators

: MORE(▲)/LESS(▼) indicators for automatic cooking

### TIME / AMOUNT INDICATORS:

h : Hour  
min : Minute  
sec : Second  
tray : Layer  
 : Cup

### ACCESSORY INFORMATION INDICATORS:

: Rack  
 : Baking tray  
 : Upper position  
 : Lower position

### COOKING MODE INDICATORS:

AUTO : Automatic cooking is selected.

MANUAL : Manual cooking is selected.

WATER OVEN : Water Oven

CONVEC OVEN : Oven

WATER GRILL : Water Grill

GRILL : Grill

PREHEAT : Preheat

STEAM : Steam High

STEAM LOW : Steam Low

STEAM PROOF : Steam Proof

PROOF : Proof

MICRO : Microwave

: Defrost

: Defrost Low

[ALL IN ONE] : Auto Sensor Cook is selected.

: Auto Sensor Cook (Grill)

\* With "❄", frozen ingredients are included.

: Auto Sensor Cook (Bake)

\* With "❄", frozen ingredients are included.

: Auto Sensor Cook (Stir Fry)

\* With "❄", frozen ingredients are included.

: Auto Sensor Cook (Steam)

\* With "❄", frozen ingredients are included.

# IMPORTANT INSTRUCTIONS

## Read Carefully Before Cooking with Water

### WATER TANK

To fill the water tank with room temperature water suitable for drinking (filtered) is a must for both Automatic and Manual Cooking. Be sure to follow the directions below.

1. Pull the water tank toward you to remove. (Figure 1)
2. Wash the water tank and lid for the first time.
3. Fill the water tank with **room temperature water suitable for drinking (filtered)**

**There are 2 Water Levels.** (Figure 2) Do not fill the water tank over the 2 mark (MAX).

4. Make sure the lid is closed firmly.
5. Install the water tank by pushing firmly. (Figure 3)
6. After cooking, empty the water tank and wash the water tank and the lid.

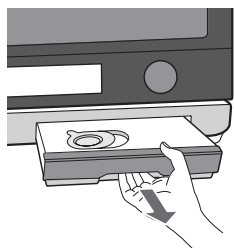
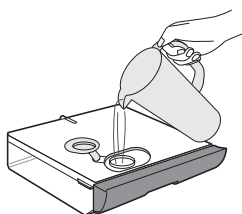

Figure 1



Water Level 1



Water Level 2

Figure 2

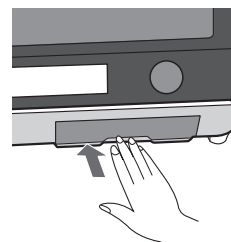

Figure 3

### NOTES:

1. Do not use any other liquids like distilled water, R.O water, mineral water and etc.
2. An insufficient amount of water in the water tank may cause an undesired result.
3. We recommend that you empty the water tank every time after cooking. Do not leave the water tank filled with water in the oven over a day.
4. If "☒" is shown in the display during cooking, check the water tank is put correctly.
5. Do not drop or damage the water tank. Heat may cause the water tank to change shape. Do not use a damaged water tank. Contact a SERVICE CENTRE APPROVED BY SHARP.

### DRIP TRAY

Be sure to cook with drip tray in position and follow the directions below.

The drip tray is packed with the oven. Place the drip tray under the oven door as shown in Figure 4. This drip tray collects the condensation from the oven door.

**To remove the drip tray:** Pull the drip tray toward you with both hands.

\* Make sure water is not dripping down before removing the drip tray.

**To replace the drip tray:** Insert the drip tray horizontally as shown in Figure 4.

**Empty the drip tray after each time you cook.** Empty, rinse thoroughly, dry and replace. Failure to empty may cause the drip tray to overflow. Cooking repeatedly without emptying the drip tray may cause it to overflow.

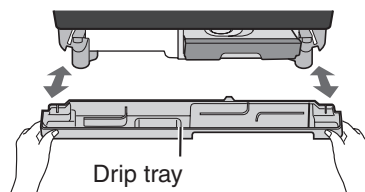

Figure 4

### WARNINGS:

1. Do not open the oven with your face close to the oven. Steam from the oven may cause burns.
2. Do not touch the water directly as water in the drip tray may be hot.



# IMPORTANT INSTRUCTIONS

## Read Carefully Before Cooking with Water

### Before cooking

1. Make sure the water tank is put with room temperature water suitable for drinking (filtered) and is installed. (See page E-6.)
2. Make sure the empty drip tray is installed. (See page E-6.)
3. Place food in the oven unless preheating is needed.

### After Cooking

1. After the oven has cooled, remove and empty the water tank, wipe oven cavity. Then empty the drip tray.
2. Perform the Drain Water function at least once a day.

### Oven Door Opening

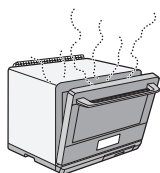

Figure 1

You can stop the door with the upper part of the oven open to exhaust steam, to cool or dry the oven cavity temporarily after cooking. (See Figure 1)

**WARNING:** Do not open the oven with your face close to the oven. Steam from the oven may cause burns.

**NOTE:** Avoid opening and closing the door during cooking as the oven cavity temperature drops suddenly, which may affect the result.

## Superheated Steam Level for Manual Cooking

On MANUAL Water Oven and Water Grill, you can select the quantity of Superheated Steam. This function is also available during the cooking.

Superheated Steam Level		Examples
	Display	
- Water Oven 3 - Water Grill 3		<ul style="list-style-type: none"> <li>• To quickly raise oven temperature for such items as frozen foods and pieces of meat.</li> <li>• Applies ample steam when starting to cook baguette for a crispy finish.</li> </ul>
- Water Oven 2 - Water Grill 2		<ul style="list-style-type: none"> <li>• Evenly cooks the inside and outside of food.</li> <li>• Most online cookbook recipes recommend Superheated Steam Level 2.</li> <li>• For breads and cream puffs, applies steam when starting to cook for a fluffy finish.</li> </ul>
- Water Oven 1 - Water Grill 1		<ul style="list-style-type: none"> <li>• Concentrates baking on the outside to prevent dryness.</li> </ul>
- Water Oven 0 - Water Grill 0		<ul style="list-style-type: none"> <li>- No Superheated Steam</li> </ul> <p>For stopping to generate Superheated Steam. (This level is same as Oven and Grill without water)</p>
<b>THIS LEVEL IS AVAILABLE DURING THE COOKING ONLY.</b>		
- Oven - Grill	No Superheated steam level indicator lights.	<ul style="list-style-type: none"> <li>- No water needs for these mode.</li> </ul> <p><b>NOTE:</b> These modes cannot be changed to Water oven and Water Grill during the cooking.</p>



# IMPORTANT INSTRUCTIONS

## Drain Water Function

Perform the Drain Water function at least once a day after using water tank. It takes up to 8 minutes.

Drain Water function is very useful to prevent scale build up and the use of stale water. It causes evaporation of the internal steam system.

### PROCEDURE

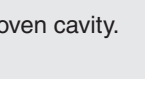
- 1 Ensure nothing is in the oven. Turn the **Knob** to select [22] Drain Water. 
- 2 Make sure the water tank is removed and press **START**. 
- 3 After the oven has cooled, wipe oven cavity. 

#### NOTE:





The water tank must be removed before starting this procedure.

## Descal Function

White or gray grains, also called scale, may form in the water circuit inside the oven during steam generation, which could cause the oven to malfunction.

When “DESCALE” is shown in the display, be sure to carry out Descal function immediately. It takes about 1 hour.

### PROCEDURE

- 1 Pure citric acid, available at some drugstores, is used for descaling. Open the lid of the water tank. Fill the water tank with water over the 1 mark. Then dissolve 2 tablespoons of pure citric acid as shown in Figure 1. 
- 2 Place a folded towel under the steam outlets as shown in Figure 2. 
- 3 Turn the **Knob** to select [24] Descal. 
- 4 Press **START**. 

- 5 When the oven has stopped, wipe oven cavity, then wring the towel and put it again as shown in Figure 2. Remove water tank, empty, rinse and refill with water over the 1 mark. Replace the water tank. 

Remove and empty the drip tray, then replace it to the oven.

Press **START**. Rinsing will start.

- 6 When rinsing has ended, remove water tank and empty. Remove the towel. Wipe oven cavity to dry. Then empty the drip tray. 

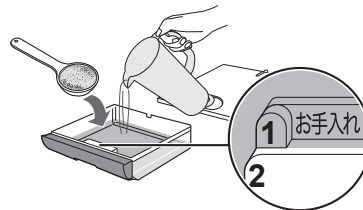

Figure 1

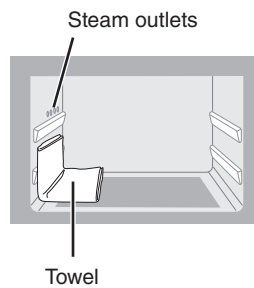

Figure 2

# BEFORE OPERATING

- Before operating your Water Oven, make sure you read and understand this operation manual completely.
- Before the oven can be used, follow these procedures:
  1. Place the drip tray correctly. See page E-6.
  2. See below for getting started.
  3. Follow directions on the right side for clean the oven before first use.

## Getting Started

Your oven has an Auto Display Off Mode.

### PROCEDURE

- 1** Plug the oven into a power point. "0" (initial display) will appear on the display.

#### CAUTION:

1. With the initial display, if you do not operate the oven for 1 minute or more (i.e. after closing the door, or pressing **STOP/CLEAR**, the display will be blank until you open and close the oven door,
2. After cooking, it will take 1 - 30 minutes to be blank depending the following condition.
  - The oven door is close.
  - The initial display (displayed only 0) is shown.
  - "⚠" is not shown in the display.

## Clear

1. Press **STOP/CLEAR** if you make a mistake during programming.
2. Cancel a programme during cooking.
3. Return the initial display (displayed only 0).

#### NOTE:

To stop the oven temporarily during cooking, open the door. To restart cooking, close the door and press **START**.

# CLEAN THE OVEN BEFORE FIRST USE

The steam generator heats the water which is used for cooking. It should be cleaned before the first use to get rid of any odour in the oven cavity. Clean the oven with [25] Clean Oven (First Use). It takes about 20 minutes. You may notice some smoke and odour during this process. This is normal. The oven is not out of order.

#### PREPARATION

1. Ventilate the room.
2. Make sure that the empty drip tray is installed.
3. Make sure the water tank is filled to the 1 mark with room temperature water suitable for drinking (filtered) and is installed.

### PROCEDURE

- 1** Ensure nothing is in the oven. Turn the **Knob** to select [25] Clean Oven (First Use).



- 2** Press **START**.



- 3** When the oven is cool, remove water tank and empty. Wipe oven cavity. Remove and empty the drip tray, then replace it to the oven.

#### WARNINGS:

1. The oven door, outer cabinet and oven cavity will become hot.
2. Do not open the oven with your face close to the oven. Steam from the oven may cause burns.

# AUTOMATIC COOKING

## Notes for Automatic Cooking

1. When using the automatic features, carefully follow the instructions provided in each Menu Guide to achieve the best result. If the instructions are not followed carefully, the food may be overcooked or undercooked.
2. Food weighing more or less than the quantity or weight listed in each Menu Guide, cook manually.
3. To change the final cooking or defrosting result from the standard setting, turn the **Knob** clockwise (▲) for more cooking time or counterclockwise (▼) for less cooking time after pressing **START**. Refer to page E-20.
4. When covering with plastic wrap, cover loosely. Do not reheat with a sealed container. Remove the lid.
5. Do not place any non heat-resistant containers while the oven cavity is hot. They may melt.
6. After cooking, the display may show “

## Sensor Reheat (Microwave cooking)

Sensor Reheat automatically reheats all the food shown in the Sensor Reheat Menu Guide on page E-31.

### SPECIAL NOTE for SENSOR REHEAT:

1. Wipe off any moisture from the outside of cooking containers and the interior of the oven with a dry cloth or paper towel prior to reheating.
2. Place food in the center of the oven floor.
3. Never use Sensor Reheat to heat any beverages to prevent the eruptive boiling. BEVERAGE is suitable for heating the beverages. See page E-11.

\* Suppose you want to reheat 1 serve of rice.

## PROCEDURE

- 1 Press **SENSOR REHEAT**.



\*The progress is shown with the flashing bar. (4 bars will light before finishing the cooking) The remaining cooking time may be appeared.

- 2 After cooking, “EXTEND” will appear. If you wish to extend cooking time, turn the **Knob** to add time and press **START** within 1 minute. If not, press **STOP/CLEAR**.

### NOTES:





1. It is not necessary to enter the weight of the food.
2. To reheat other foods or foods above or below the weights allowed on Sensor Reheat Menu Guide, reheat manually. See Microwave on page E-15.
3. Do not use the baking tray and metal rack.

# AUTOMATIC COOKING

## Defrost (Microwave with Steam cooking)

Defrost automatically defrosts all the foods shown in the Defrost Menu Guide on page E-32.

Defrost has two options:

Option	Pad	Display	Doneness
1. Defrost	 x1		For immediate cooking
2. Defrost Low	 x2		For harder texture to divide food partly

**Water Level:** 1 or more

\* Suppose you want to defrost 200 g sliced meat with Defrost.

### PROCEDURE

**1** Press **DEFROST** once.  x 1

**2** Press **START**. 

\* The progress is shown with the flashing bar. (4 bars will light before finishing the cooking)

**3** After cooking, “EXTEND” will appear. If you wish to extend defrosting time, turn the **Knob** to add time and press **START** within 1 minute. If not, press **STOP/CLEAR**.  
After defrosting, remove and empty the water tank, wipe oven cavity. Then empty the drip tray.

### NOTES:

1. It is not necessary to enter the weight of the food.
2. To defrost other foods or foods above or below the weights allowed on Defrost Menu Guide, use time and 200W microwave power. See Microwave on page E-15.
3. Defrost can be done without water, but the doneness will be slightly different.
4. Do not use the baking tray and metal rack.
5. While the oven cavity temperature is too high, you cannot use Defrost. The display will show “U 04”.



## Beverage (Microwave cooking)

Beverage automatically reheats beverages shown in the Beverage Menu Guide on page E-32.

\* Suppose you want to reheat 4 cups of milk.

### PROCEDURE

**1** Press **BEVERAGE**. 

**2** Turn the **Knob** to select the desired amount (4 ). 

**3** Press **START**. 

\* Remaining cooking time will be appear after about 30sec.

**4** After cooking, “EXTEND” will appear. If you wish to extend cooking time, turn the **Knob** to add time and press **START** within 1 minute. If not, press **STOP/CLEAR**.

### NOTE:





Do not use the baking tray and metal rack.

# AUTOMATIC COOKING

## Auto Sensor Cook (ALL IN ONE) (Water Oven/Steam cooking)

Auto Sensor Cook automatically cooks meat, fish and vegetables at the same time. The sensor controls the heat and cooking time depending on the type of ingredients, initial temperature and quantity.

Auto Sensor Cook has four options:

Option	Display	Weight range	Water level	Accessory	Food position	Cooking time (min.)	
						No Frozen	With Frozen
1. Grill		Up to 1 kg	1 or more	Baking tray Rack	Upper	20 - 25	25 - 30
2. Bake				Baking tray		20 - 30	25 - 30
3. Stir Fry				Baking tray		15 - 20	20 - 25
4. Steam		Up to 800 g	2 (MAX)	Baking tray Rack		15 - 20	20 - 25

- Additional 2 choices are available depending on having frozen ingredients or not:  
For no frozen ingredient, press **AUTO SENSOR COOK** once.  
For having any frozen ingredients, press **AUTO SENSOR COOK** twice.
- Refer to Auto Sensor Cook Menu Guide on page E-33 and online cookbook, ensure the suitable menus and follow to SHARP instructions.

\* Suppose you want to cook a 0.5 kg food with no frozen ingredient by Stir Fry.

### PROCEDURE

**1** Press **AUTO SENSOR COOK** once.



**2** Turn the **Knob** until desired option (Stir Fry) appears.



**3** Press **START**.



\* The progress is shown with the flashing bar. (When the sensor detects the vapour from the food, the remaining cooking time will appear)

**4** After cooking, "EXTEND" will appear. If you wish to extend cooking time, turn the **Knob** to add time and press **START** within 1 minute. If not, press **STOP/CLEAR**.

After the oven has cooled, remove and empty the water tank, wipe oven cavity. Then empty the drip tray.

#### WARNINGS:

1. The oven door, outer cabinet and oven cavity will become hot. Use thick oven gloves when adding or removing foods to prevent burns.
2. Do not open the oven with your face close to the oven. Steam from the oven may cause burns.

#### NOTE:

It is not necessary to enter the weight of the food.

# AUTOMATIC COOKING

## Auto Menu (Water Oven/Water Grill/Steam/Microwave cooking)

Auto Menu has 15 menus:

1. Crispy Reheat\*
2. Steam Reheat\*
3. Reheat Bread\*
4. Reheat Frozen Food\*
5. Reheat as Temperature\*
6. Grilled Chicken
7. Deep Fried Chicken
8. Grilled Fish
9. Steamed Vegetables\*
10. Baked Sweet Potato
11. Toast
12. Breakfast Set
13. Sponge Cake
14. Cream Puff
15. Dried Food

Refer to Auto Menu Guide on page E-34-38, and online cookbook, ensure the suitable menus and follow to SHARP instructions.

### For Menus except for Menu No. 5

\* Suppose you want to grill fish for 4 servings.

#### PROCEDURE

- 1 Turn the **Knob** until desired menu number (8-4) appears.



- 2 Press **START**.



- 3 After cooking, "EXTEND" will appear. If you wish to extend cooking time, turn the **Knob** to add time and press **START** within 1 minute. If not, press **STOP/CLEAR**.

If necessary, after the oven has cooled, remove and empty the water tank, wipe oven cavity. Then empty the drip tray.

### Tips for menu No.1 - 3:

For reheating frozen item, turn the **Knob** slightly right until "❄" is shown with the menu number.

### For menu No. 5

\* Suppose you want to heat butter to 20°C.

#### PROCEDURE

- 1 Turn the **Knob** until desired menu number (5) appears.



- 2 Press **ENTER** to confirm.



- 3 Turn the **Knob** until desired temperature (20°C) appears.



- 4 Press **START**.



- 5 After cooking, "EXTEND" will appear. If you wish to extend cooking time, turn the **Knob** to add time and press **START** within 1 minute. If not, press **STOP/CLEAR**.

#### WARNINGS:

1. The oven door, outer cabinet and oven cavity will become hot. Use thick oven gloves when adding or removing foods to prevent burns.
2. Do not open the oven with your face close to the oven. Steam from the oven may cause burns.

#### NOTES:

1. Menu No. 5 cannot be programmed with More or Less Time Adjustment.
2. For the menus with \*, it is not necessary to enter the weight of food.

# MANUAL COOKING

Manual Cooking is an option in Convection, Grill, Steam, Proof and Microwave.  
Refer to the Manual Cooking Chart. The chart gives information on each setting.

## Manual Cooking Chart

Option	Preheat*	Superheated Steam level	Temp/ Microwave range	Adjustment during cooking		Time range	Water Tank	
				Superheated Steam level	Temp/ Microwave			
Convection	Water Oven	YES or NO	0 - 3	100 - 250°C	YES	YES	0 - 1h35min.	YES
	Oven	YES or NO	-	100 - 250°C	-	YES	0 - 1h35min.	NO
Grill	[16] Water Grill	YES or NO	0 - 3	-	YES	-	0 - 45min.	YES
	[16] Grill	YES or NO	-	-	-	-	0 - 45min.	NO
Steam	[17] Steam High	NO	-	100°C	-	-	0 - 30min.	YES
	[18] Steam Low	NO	-	70 - 95°C	-	NO	0 - 45min.	YES
Proof	[19] Steam Proof	NO	-	35 - 45°C	-	NO	0 - 2 hours	YES
	[20] Proof	NO	-	30 - 45°C	-	NO	30°C : 0 - 8 hours 35 - 45°C: 0 - 2 hours	NO
Microwave	-	-	800/600/500/ 200 W	-	NO	0 - 1hour**	NO	

\* Preheat temperature is held for 20 minutes.

\*\* Time range for 800W is 0-10 minutes, and for 600 W is 0- 30 minutes.

## SUPERHEATED STEAM LEVEL

Your oven can be programmed for the quantity of Superheated Steam from level 0 to level 3. See page E-7.

## COOKING TIME INPUT

Your oven can be programmed for up to 8 hours depending on the cooking mode. Refer to the Manual Cooking Chart. The input unit increment varies from 10 seconds to 30 minutes, depending on the total length of time and cooking mode as shown in the table below.

## TEMPERATURE INPUT

Your oven can be programmed for temperatures from 30°C to 250°C depending on the cooking mode. Refer to the Manual Cooking Chart. The temperature can be adjusted as shown in the table below.

ITEM	INPUT STEP
Temperature Convection Steam Proof	10°C per step (170°C is initial temperature) 5°C per step (70°C is initial temperature) 5°C per step (40°C is initial temperature)
Cooking Time Convection	0 - 30 min. : 1 min. per step (Initial setting time: 15 min.) 30 min. - Max. : 5 min. per step
Cooking Time Grill Steam	0 - 15 min. : 30 sec. per step (Initial setting time: 15 min.) 15 min. - Max. : 1 min. per step
Cooking Time Proof	0 - 1 hour : 5 min. per step (Initial setting time: 30 min.) 1 hour - Max. : 30 min. per step
Cooking Time Microwave	0 - 5 min. : 10 sec. per step 5 - 10 min. : 30 sec. per step 10 - 30 min. : 1 min. per step 30 min. - Max. : 5 min. per step  * 0 - 10 min. : 10 sec. per step (for 200 W) 0 - 1 min.: 5 sec. per step (for 800 W) 1 - 10 min.: 10 sec. per step (for 800 W)



# MANUAL COOKING

## Microwave

Microwave is fast and convenient for cooking, reheating and defrosting.

There are 4 different power levels.

\* Suppose you want to cook for 5 minutes on 500W.

### PROCEDURE

**1** Press **MANUAL MICRO**.



**2** Turn the **Knob** to select power level (500 W), and press **ENTER** to confirm.



**3** Turn the **Knob** to enter desired cooking time (5 min.)



**4** Press **START**.



**5** After cooking, "EXTEND" will appear. If you wish to extend cooking time, turn the **Knob** to add time and press **START** within 1 minute. If not, press **STOP/CLEAR**.

#### NOTE:

Do not use the baking tray and metal rack.

# MANUAL COOKING

## Convection

Convection has 2 functions, Oven and Water Oven, and each function has 2 options, With Preheat or Without Preheat. You can cook with one or two layers. Refer to online cookbook, ensure the suitable menus and follow to SHARP instructions.

**Water Level:** 1 or more (for Water Oven only)

**Food Position:** Lower

### Cooking with Preheat

\* Suppose you want to cook 1 layer for 45 minutes on Water Oven 2 at 160°C.

#### PROCEDURE

**1** No food in the oven.  
\* Depending on the menu, only accessories should be put. Press **MANUAL COOK**.

**2** Turn the **Knob** to select desired superheated steam level (2: ) , then press **ENTER** to confirm.



**3** Turn the **Knob** to select “PREHEAT” and desired layer (1 tray), then press **ENTER** to confirm.



**4** Turn the **Knob** to enter desired temperature (160°C), then press **START** to preheat.



**5** When preheat is over, place food in the oven. Close the door.

**6** Turn the **Knob** to enter desired cooking time (45 min.)



**7** Press **START**.



**8** After cooking, “EXTEND” will appear. If you wish to extend cooking time, turn the **Knob** to add time and press **START** within 1 minute. If not, press **STOP/CLEAR**. After the oven has cooled, remove and empty the water tank, wipe oven cavity. Then empty the drip tray.

### Cooking without Preheat

\* Suppose you want to cook 2 layers for 45 minutes on Oven at 160°C

#### PROCEDURE

**1** Press **MANUAL COOK**.



**2** Confirm flashing “CONVECOVEN” and “”; then press **ENTER**.



**3** Turn the **Knob** to select desired layer (2 tray) without flashing “PREHEAT”, then press **ENTER** to confirm.



**4** Turn the **Knob** to enter desired temperature (160°C) and press **ENTER** to confirm.



**5** Turn the **Knob** to enter desired cooking time (45 min.)



**6** Press **START**.



**7** After cooking, “EXTEND” will appear. If you wish to extend cooking time, turn the **Knob** to add time and press **START** within 1 minute. If not, press **STOP/CLEAR**. After the oven has cooled, remove and empty the water tank, wipe oven cavity. Then empty the drip tray.

#### WARNING:

The oven door, outer cabinet and oven cavity will become hot. Use thick oven gloves when adding or removing foods to prevent burns.

#### NOTES:

1. If the oven door is not opened after preheating, the oven will hold the preheat temperature for 20 minutes. After that, the display will return to the initial one and you have to reprogram from the step 1.
2. You can change the oven temperature during cooking. See page E-20.
3. You can change the Superheated Steam Level during cooking. See page E-20.

# MANUAL COOKING

## Grill

Grill has 2 functions, Grill and Water Grill, and each function has 2 options, With Preheat or Without Preheat.

Refer to the online cookbook, ensure the suitable menus and follow to SHARP instructions.

**Water Level:** 1 or more (for Water Grill only)

**Food Position:** Upper

### Cooking with Preheat

\* Suppose you want to cook for 20 minutes on Water Grill 2.

#### PROCEDURE

- 1 No food in the oven.  
\* Depending on the menu, only accessories should be put.  
  
Turn the **Knob** to select Grill (16) and “PREHEAT”; then press **ENTER** to confirm.



- 2 Turn the **Knob** to select Water Grill and desired superheated steam level (2: 2, 3, 4, 5).



- 3 Press **START** to preheat.



- 4 When preheat is over, place food in the oven. Close the door.

- 5 Turn the **Knob** to enter desired cooking time (20 min.)



- 6 Press **START**.



- 7 After cooking, “EXTEND” will appear. If you wish to extend cooking time, turn the **Knob** to add time and press **START** within 1 minute. If not, press **STOP/CLEAR**.  
After the oven has cooled, remove and empty the water tank, wipe oven cavity. Then empty the drip tray.

### Cooking without Preheat

\* Suppose you want to cook for 20 minutes on Grill.

#### PROCEDURE

- 1 Turn the **Knob** to select Grill (16 without flashing “PREHEAT”), then press **ENTER** to confirm.



- 2 Confirm flashing “GRILL” and “”, then press **ENTER**.



- 3 Turn the **Knob** to enter desired cooking time (20 min.).



- 4 Press **START**.



- 5 After cooking, “EXTEND” will appear. If you wish to extend cooking time, turn the **Knob** to add time and press **START** within 1 minute. If not, press **STOP/CLEAR**.  
After the oven has cooled, remove and empty the water tank, wipe oven cavity. Then empty the drip tray.

#### WARNING:

The oven door, outer cabinet and oven cavity will become hot. Use thick oven gloves when adding or removing foods to prevent burns.

#### NOTES:

1. If the oven door is not opened after preheating, the oven will hold the preheat temperature for 20 minutes. After that, the display will return to the initial one and you have to reprogram from the step 1.
2. You can change the Superheated Steam Level during cooking. See page E-20.

# MANUAL COOKING

## Steam

Steam has 2 functions: Steam High and Steam Low. Steam cooks food gently without destroying shape, colour or aroma.

Refer to the online cookbook, ensure the suitable menus and follow to SHARP instructions.

### Steam High

Steam High cooks food at 100°C.

**Water Level:** 2 (MAX)

**Food Position:** Upper

\* Suppose you want to cook for 20 minutes on Steam High.

### PROCEDURE

- 1 Turn the **Knob** to select Steam High (17), then press **ENTER** to confirm.



- 2 Turn the **Knob** to enter desired cooking time (20 min.)



- 3 Press **START**.



- 4 After cooking, “EXTEND” will appear. If you wish to extend cooking time, turn the **Knob** to add time and press **START** within 1 minute. If not, press **STOP/CLEAR**.  
After the oven has cooled, remove and empty the water tank, wipe oven cavity. Then empty the drip tray.

### WARNING:

The oven door, outer cabinet and oven cavity will become hot. Use thick oven gloves when adding or removing foods to prevent burns.

### Steam Low

Steam Low cooks food at 70 - 95°C.

**Water Level:** 2 (MAX)

**Food Position:** Upper

\* Suppose you want to cook for 20 minutes on Steam Low (90°C).

### PROCEDURE

- 1 Turn the **Knob** to select Steam Low (18), then press **ENTER** to confirm.



- 2 Turn the **Knob** to enter desired temperature (90°C) and press **ENTER** to confirm.



- 3 Turn the **Knob** to enter desired cooking time (20 min.).



- 4 Press **START**.



- 5 After cooking, “EXTEND” will appear. If you wish to extend cooking time, turn the **Knob** to add time and press **START** within 1 minute. If not, press **STOP/CLEAR**.  
After the oven has cooled, remove and empty the water tank, wipe oven cavity. Then empty the drip tray.

### WARNING:

The oven door, outer cabinet and oven cavity will become hot. Use thick oven gloves when adding or removing foods to prevent burns.

### NOTE:

While the oven cavity temperature is too high, you cannot use Steam Low. The display will show “U 04”.

# MANUAL COOKING

## Proof

Proof has 2 functions, Steam Proof and Proof. Use Proof to aid dough rising when making regular or sweet yeast breads.

### Steam Proof

This function proofs dough while adding steam.

**Water Level:** 1 or more

**Food Position:** Lower

\* Suppose you want to proof for 50 minutes on Steam Proof (40°C)

## PROCEDURE

- 1 Turn the **Knob** to select Steam Proof (19), then press **ENTER** to confirm.



- 2 Turn the **Knob** to enter desired temperature (40°C) and press **ENTER** to confirm.



- 3 Turn the **Knob** to enter desired cooking time (50 min.).



- 4 Press **START**.



- 5 After cooking, "EXTEND" will appear. If you wish to extend cooking time, turn the **Knob** to add time and press **START** within 1 minute. If not, press **STOP/CLEAR**.  
Remove and empty the water tank, wipe oven cavity. Then empty the drip tray.

### NOTES:

1. While the oven cavity temperature is too high, you cannot use Steam Proof. The display will show "U 04".
2. Cover the food container with a dry kitchen cloth.

## Proof

This function proofs dough without steam. The water tank is not necessary.

**Food Position:** Lower

\* Suppose you want to proof for 2 hours 30 minutes on Proof (30°C).

## PROCEDURE

- 1 Turn the **Knob** to select Proof (19), then press **ENTER** to confirm.



- 2 Turn the **Knob** to enter desired temperature (30°C) and press **ENTER** to confirm.



- 3 Turn the **Knob** to enter desired cooking time (2 h 30 min.).



- 4 Press **START**.



- 5 After cooking, "EXTEND" will appear. If you wish to extend cooking time, turn the **Knob** to add time and press **START** within 1 minute. If not, press **STOP/CLEAR**.

### NOTES:

1. While the oven cavity temperature is too high, you cannot use Proof. The display will show "U 04".
2. Cover the food container with a dry plastic wrap.

## OTHER CONVENIENT FEATURES

### Automatic Cooking Time Adjustment (More or Less Time Adjustment)

You can adjust cooking results as you like.

Should you discover that you like any automatic settings slightly more done, turn the **Knob** clockwise within 30 sec. after pressing **START**.

The display will show “▲”.

Should you discover that you like any automatic settings slightly less done, turn the **Knob** counterclockwise within 30 sec. after pressing **START**.

The display will show “▼”.

During “●” is flashing, you can change the setting. (It will disappear in about 30 sec.)

### Temperature Adjustment

To change the oven temperature during cooking in Manual Operation with Convection, simply turn the **Knob** to increase or decrease in 10°C increments and then press **ENTER**.

### Superheated Steam Level Adjustment

The Superheated Steam Level can be changed during cooking in Manual Operations with Water Oven and Water Grill. To change, press **MANUAL COOK**. Then turn the **Knob** to select desired Superheated Steam Level and then press **ENTER**.

#### NOTE:

This function is invalid during preheating and the extension cooking.

### End of Cooking Reminder

At end of cooking, the oven will signal and repeat after 1, 2 and 3 minutes unless door is opened or **STOP/CLEAR** is pressed.

### Mute the Oven

To mute the oven, press **MANUAL MICRO** for 4 sec. until the 2 short beeps sound. Then press **STOP/CLEAR**.

#### NOTES:

1. The oven will hold the setting even if the power is interrupted.
2. The following 2 signals will sound even if the oven is in the mute setting.
  - Error sound
  - Cancellation sound during oven operation
3. To restore the sound, press **MANUAL MICRO** for 4 sec. until a short beep sounds. Then press **STOP/CLEAR**.

# OTHER CONVENIENT FEATURES

## Sterilization for Kitchen Items

Sterilization has 2 options [21-1] and [21-2] depending on the heat-resistant temperature. See the right side.

\* Suppose you want to sterilize dishes with [21-1].

### PROCEDURE

- 1 Turn the **Knob** to select desired option number (21-1) appears.



- 2 Press **START**.



\* After heating, the oven will automatically go on to the cooling programme. The progress is shown with flashing bar. (4 bars will light before finishing the programme)

- 3 After sterilization, remove the baking tray slowly and horizontally.

Remove and empty the water tank, wipe oven cavity. Then empty the drip tray.

### NOTES:

1. While the oven cavity temperature is too high, you cannot use Sterilization. The display will show "U 04".
2. Check the heat-resistant temperature of each container before sterilization. Never sterilize items the heat-resistant temperature is not clarified.
3. Do not open the door or add any items during sterilization.
4. Do not remove items until the sterilization finishes to prevent burns.

### Unavailable Items:

- Items with heat-resistant temperature less than 90 °C.
- Lacquer, Bamboo, Wooden or Paper Ware
- Iron Cookware
- Dirty tableware
- Polycarbonate products
- Any other items than tableware and cookware

[21-1] Items that heat-resistant temperature is over 120 °C.  
**Time required:** Maximum 46 min. (sterilization time: about 26 min.)

### Examples:

- Plastic container (except for Polycarbonate resin)
- China, Ceramics: plate and bowl etc.
- Glassware (The items made of tempered glass, cut-glass and crystal glass may be broken)
- Metal cutlery (The items having plastic handles are not available)
- Stainless kitchen knife
- Kitchen scissors
- Baby bottle

### NOTE for Container with lid:

Check the heat-resistant temperature for each part. Some lids have lower heat-resistant temperature than their containers.

**Water Level:** 2 (MAX)

**Position:** Lower

**How to set:** Put item directly on the baking tray.

- Containers should be put face upward.
- You can put baking paper on the baking tray.

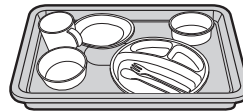

Up to 2 dishes can be stacked.

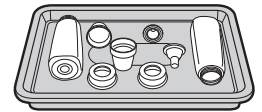

Place the baby bottle on its side and set the nipple and cap next to it.

[21-2] Items that heat-resistant temperature is over 90 °C.  
**Time required:** Maximum 33 min. (sterilization time: about 30 min.)

### Examples:

- Plastic cutting board (smaller than 29cm×39cm: 1 sheet)
- Towel (smaller than 40cm×40cm : up to 6 pieces, smaller than 36cm×90cm: up to 3 pieces)

**Water Level:** 2 (MAX)

**Position:** Upper

**How to set:** Put item on the metal rack in baking tray.

### NOTE for towel:

1. Wring water out of towels.
2. Fold the towels and stack them on the metal rack. Or roll up and put them side by side on the rack. (with less than 10 layers)

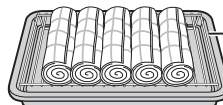

Put item on the metal rack.

\* Test organization: General Incorporated Association Kyoto Biseibutsu Kenkyusho  
 Test method: Live bacteria measurement  
 Sterilization method: Removal by heat using water vapor  
 Test results: More than 99.0% of bacteria eliminated  
 Test subject: 21-1: Ceramic rice bowl  
 21-2: Towel

In no case does sterilization completely eliminate bacteria.

# CLEANING AND CARE

## Key Point for Cleaning - Immediately and frequently!

The food splashes and oily meat juice, remaining on the oven interior walls will get stuck and hard to remove if it is not cleaned immediately and after each use. The usage of the Steam function will assist in this cleaning process.

## CLEAN THE OVEN AT REGULAR INTERVALS -

Keep the oven clean and remove any food deposits, or it could lead to deterioration of the surface. This could adversely affect the life of the appliance and possibly result in a hazardous situation.

### IMPORTANT CAUTIONS:

- DISCONNECT THE POWER CORD BEFORE CLEANING.
- BEFORE CLEANING, MAKE SURE THE OVEN IS COMPLETE COOL.
- DO NOT USE OVEN CLEANERS, CAUSTIC CLEANERS (ACIDIC/ALKALINE), ABRASIVE, HARSH CLEANERS OR SCOURING PADS ON ANY PART OF YOUR OVEN.
- DO NOT USE A STEAM CLEANER.

## Oven Cleaning - Exterior

The outside may be cleaned with mild soap and warm water, wipe clean with a damp cloth. Avoid the use of harsh abrasive cleaners. Keep the ventilation openings free of dust.

## Door

Wipe the door and window on both sides, the door seals and adjacent parts frequently with a damp cloth to remove any spills or splatters. Do not use harsh abrasive cleaners or sharp metal scrapers to clean the oven door glass since they can scratch the surface, which may result in shattering of the glass.

## Control Panel

Care should be taken in cleaning the control panel. Wipe the panel with a cloth dampened slightly with water only. Dry with a soft cloth. Do not scrub or use any sort of chemical cleaners.

## Oven Cleaning - Interior

### IMPORTANT INFORMATION:

- **After every use:** Wipe the oven walls with a soft cloth and warm water (or mild soapy water) while the oven is still warm. Using the oven without cleaning may lead to splatters to get stuck.
- Do not use caustic cleaners (acidic/alkaline), spray type cleaners, abrasive or harsh cleaners or scouring pads as it may damage the surface of paint coating.

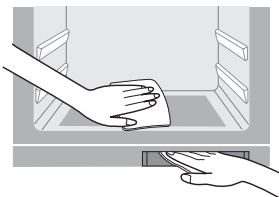

## For removal of OIL AND FOOD SPLASHES on oven walls:

1. Fill the water tank with room temperature water suitable for drinking (filtered) through the lid to the 2 mark (MAX).
2. Operate the oven with [17] Steam High for 10 minutes without food. See page E-18 in the operation manual.
3. After the steaming, wipe the dirt in the oven interior with a dry soft cloth while the oven is still warm.

## For removal of the ODOUR (STEAM CLEAN):

Carry out Steam Clean function below. It is not a self-cleaning function. It will take approximately 20 minutes for the cleaning cycle.

### PREPARATION

1. Make sure to wipe the oven walls with a soft cloth and warm water (or mild soapy water) before carrying out Steam Clean.
2. Make sure that the water tank is filled with room temperature water suitable for drinking (filtered) to the 1 mark and is installed. (See page E-6.)
3. Make sure that the empty drip tray is installed. (See page E-6.)

## PROCEDURE

- 1 Turn the **Knob** to select [23] Steam Clean.



- 2 Press **START**.



Allow the oven to cool to prevent burns. Then open the door and remove any residue carefully with a soft damp cloth. Finally, remove and empty the water tank. Then empty the drip tray.



# CLEANING AND CARE

---

## Door Seals

Always keep the door seals clean to prevent any damage. If water condenses inside the door seals, wipe dry with a soft cloth. Polish with another soft cloth. Do not use a chemical or abrasive cleaner on these surfaces. Care should be taken not to rub, damage, pull or move the seals. Before cooking, always check that door seals is lying smooth and flat. If not, steam will leak from the door. Do not use the oven if it has a damaged door seals. Consult a SERVICE CENTRE APPROVED BY SHARP.

## Baking Tray / Rack

Wash baking tray and rack after cooking with a mild soap or detergent solution, rinsing and polishing dry. Do not use harsh cleaners, sharp metal scrapers or stiff brushes to prevent damage to the surface.

## Water Tank and Water Tank Lid

After cooking, wash in a mild soap or detergent solution with a soft damp cloth or sponge, rinse and polish dry. Do not wash in the dishwasher. Do not use harsh cleaners, sharp metal scrapers or stiff brushes on the water tank and water tank lid.

## Drip Tray

Empty drip tray after cooking, wash in a mild soap or detergent solution with a soft damp cloth or sponge, rinse, polish dry and replace below the oven front. Do not wash in the dishwasher.

## Descaling within the Oven's Steam Parts

During steam production, scale may form in the steam generator. To remove scale, carry out descale function when "DESCALE" is shown in the display. See page E-8 for complete instructions.

# TROUBLESHOOTING CHART

If “C with number” is displayed or you think the oven is not working properly, check the chart below before consulting a SERVICE CENTRE APPROVED BY SHARP. This will help to prevent unnecessary service calls.

- Repairs and Modifications: Do not attempt to operate the oven if it is not working properly.
- Outer cabinet & Lamp Access: Never remove the outer cabinet to avoid the possibility of electric shock or burns.

## Error Message/Information Message

DISPLAY	ACTION
U 03	The amount of food to be cooked is too small. Press <b>STOP/CLEAR</b> and increase the amount or set the cooking time to less than 5 minutes. After oven cooking and then heating with the microwave while the inside is still hot, this may appear. If this occurs, allow the inside of the oven to cool.
U 04	The oven is too hot to use Defrost, Auto Menu (menu No. 5), [18] Steam Low, [19] Seam Proof, [20] Proof or [21] Sterilization. Remove food from oven and allow to cool until the message clears.
U 11	Remove water tank. If the water tank is in the oven, [22] Drain Water function will not start. Remove the water tank before starting Drain Water.
U 15	The water in the water circuit inside the oven is frozen. The oven may not operate properly. Operate the oven with Oven (1 layer at 200°C) without food and preheat for 5 minutes. See page E-16.
C number: ←→ 888 Flash alternately.	Due to technical error, contact a SERVICE CENTRE APPROVED BY SHARP.
≡DESCALE≡	Descaling is necessary. Follow step-by-step instructions for descaling. See page E-8.
D (Time appearing in the display is counting down very rapidly.)	The oven is in the Demonstration mode. This feature is mainly for use by retail outlets. To cancel, press <b>STOP/CLEAR</b> until it beeps, and then press it 4 more times.
≡☒≡	Check the water tank is put correctly.

# TROUBLESHOOTING CHART

The following situations are normal and are not signs that the oven is malfunctioning.

QUESTION / SITUATION		ANSWER
Control panel / power supply	The display is black / blank.	<ul style="list-style-type: none"> <li>* Open the door and close.</li> <li>* Check the power plug is properly connected to a suitable wall outlet.</li> <li>* Check the wall socket and fuse are functioning properly.</li> <li>* Disconnect the power cord, wait for a minute, then reconnect.</li> </ul>
	Electrical power supply is interrupted during cooking.	<ul style="list-style-type: none"> <li>* The programmed cooking time and mode will be cancelled.</li> <li>* Continue to cook with manual mode.</li> </ul>
	Oven light is off during PROOF mode.	Normal operation to prevent bread dough from drying on the surface.
	Oven light is off during operating in option No. [22] - [25].	This is normal operation.
	The display does not go off.	When the display shows "  ", the display will not go off.



# TROUBLESHOOTING CHART

The following situations are normal and are not signs that the oven is malfunctioning.

QUESTION / SITUATION		ANSWER
Steam	Water is found inside the oven when the door is opened.	Steam has condensed inside the oven. Wipe dry with a soft cloth or a sponge after cooling.
	Steam comes out of the air ventilation openings at the top of the oven.	It is normal for used steam to come from the air ventilation opening on the top of the oven.
	Condensed water can be seen in the oven cavity.	This operation is normal. Steam has condensed on the oven floor. Wipe dry with a soft cloth or a sponge after cooling.
	Steam comes from the door during cooking.	Check the door sealings to make sure it is lying smoothly and flat.
Noise / Sound	No sound just after pressing <b>START</b> .	The fan will operate depending on the oven internal temperature etc. No sound may cause at the beginning of the cooking, however, it is normal.
	Noise after cooking.	The cooling fan will operate until the oven is cool. The fan may continue to operate up to 10 minutes depending on the oven and parts temperatures.
	Noise when cooking with high temperature.	High temperatures may cause expansion of the oven's components. This is normal.
Smoke / Aroma	When using the oven for the first time, it may smoke or smell.	See page E-9 for step-by-step instructions for cleaning the oven before the first use.
	The oven cavity smells after cooking.	See "For removal of the ODOUR:" on page E-22 for step-by-step instructions for removing the aroma.
	When a lot of smoke is emitted from the food during grilling.	Before cooking, pour 1 cup (200ml) of water into the baking tray (under the splash guard) to reduce the smoking emitted from the food. If you pour the water, extend the cooking time by 10-20%. <b>Never pour water during the cooking to prevent the burn caused by very hot splashes.</b> <b>WARNINGS:</b> 1. The oven door, outer cabinet and oven cavity will become hot. Use thick oven gloves when adding or removing foods to prevent burns. 2. Do not open the oven with your face close to the oven. Steam from the oven may cause burns.
Others	Time appearing in the display is counting down very rapidly.	Check the column of "D" on page E-24 and cancel.
Food spatters	It is difficult to remove food spatters stuck on the oven walls.	See "For removal of OIL AND FOOD SPLASHES on oven walls:" on page E-22. It is important to clean the oven interior after every use.

# SERVICE CALL CHECK

Check the following before calling service:

1. Place one cup of water (approx. 250 ml) in a glass measure in the oven and close the door securely. Programme the oven for one minute on Microwave 800 W. At this moment:
  - A. Does the oven lamp light? Yes \_\_\_\_\_ No \_\_\_\_\_
  - B. Does the cooling fan work? Yes \_\_\_\_\_ No \_\_\_\_\_  
(Put your hand over the ventilation openings.)
  - C. Does the Microwave icon  appear in the display? Yes \_\_\_\_\_ No \_\_\_\_\_
  - D. After one minute, did audible signals sound? Yes \_\_\_\_\_ No \_\_\_\_\_
  - E. Is the water inside the oven hot? Yes \_\_\_\_\_ No \_\_\_\_\_
2. Remove water from the oven and programme the oven for 5 minutes on Oven (1 layer, 250°C).
  - A. Does the Oven icon  appear in the display? Yes \_\_\_\_\_ No \_\_\_\_\_
  - B. After the oven stops, is inside of the oven hot? Yes \_\_\_\_\_ No \_\_\_\_\_
3. Fill the water tank with water and replace. Operate the oven for 3 minutes on Steam High.
  - A. Does the Steam icon  appear in the display? Yes \_\_\_\_\_ No \_\_\_\_\_
  - B. After the oven stops, is the inside of the oven filled with steam? Yes \_\_\_\_\_ No \_\_\_\_\_

If "NO" is the answer to any of the above questions, please check your wall socket and the fuse in your meter box. If both the wall socket and the fuse are functioning properly, CONTACT YOUR NEAREST SERVICE CENTRE APPROVED BY SHARP.

**IMPORTANT:** If the display shows nothing even if the power supply plug is properly connected, the Auto Display Off Mode may be in operation. Open and close the oven door to operate the oven. See "Getting Started" on page E-9.

## NOTES:

1. If time in the display is counting down very rapidly, check Demonstration Mode. (Please see page E-24 for detail.)
2. If you cook the food over 3 minutes on Microwave 800 W power level, output power will be reduced to avoid overheating.

# SPECIFICATIONS

AC Line Voltage	:	Refer to the rating label.
AC Power Required	:	
Microwave	:	1.34 kW
Convection	:	1.41 kW
Microwave Output Power	:	800 W* (IEC test procedure)
Microwave Frequency	:	2450 MHz (Class B/Group 2)**
Outside Dimensions	:	500 mm(W) x 420 mm(H) x 475 mm(D)***
Cavity Dimensions	:	400 mm(W) x 244 mm(H) x 316 mm(D)
Oven Capacity	:	31 litre****
Weight	:	Approx. 25 kg

\* This measurement is based on the International Electrotechnical Commission's standardised method for measuring output power.

\*\* This is the classification of ISM (Industrial, Scientific and Medical) equipment described in the International Standard CISPR11.

\*\*\* The depth does not include the door opening handle.

\*\*\*\* Internal capacity is calculated by measuring maximum width, depth and height. Actual capacity for holding food is less.

# COOKING GUIDES

## About Your Oven

This Operation Manual is valuable: read it carefully and always save it for reference.

Be aware that, unlike microwave-only ovens, Water Ovens have a tendency to become hot during cooking with **Convection, Grill or Steam**.

The oven is for food preparation or sterilization of kitchen items only. It should not be used to dry clothes or newspapers.

## About Cooking Options

Your oven has a variety of cooking options that are divided into automatic and manual. Convection, Grill, Steam and Microwave have both automatic and manual choices.

### Water Oven / Water Grill

Superheated Steam is combined with Convection/Grill heating, which can roast or bake foods and allow excess fats to be removed. These foods retain moisture. Meats and poultry are brown, juicy and flavourful.

### Oven/Grill

Oven/Grill browns, bakes, broils and crisps a wide variety of foods. Cookies, cakes, breads, muffins, biscuits and rolls can be baked on one or two levels.

### Steam/Proof

Steam cooks foods gently while retaining moisture, natural flavours and nutrients. Proof aids dough rising when making regular or sweet yeast breads.

### Microwave (Defrost)

Microwave is fast and convenient for cooking and defrosting.

# COOKING GUIDES

## About Utensils and Coverings

The chart below will help you decide what utensils and coverings should be used in each mode.

Utensils - Coverings \ Cooking Mode	Convection/Grill	Steam/Proof	Microwave (Defrost)
Aluminium Foil, Metal, Foil Containers	YES	YES	NO* Only use aluminum foil under the conditions described in this manual.
China, Ceramics	YES Oven-proof porcelain, pottery, glazed earthenware and bone china are usually suitable. Do not use the container if it has a flaw.	YES	YES Check manufacturer's recommendation for being microwave safe. Do not use the container if it has a flaw.
Heat-resistant Glassware	YES Care should be taken if using fine glassware as it can break or crack if heated suddenly.	YES	YES
Plastic/Polystyrene Containers, Plastic Wrap heat-resistant temp. over 140°C	NO	YES Care must be taken as some containers warp, melt or discolour at high temperatures.	YES Use microwave-safe plastic containers for reheating and defrosting. Some microwave-safe plastics are not suitable for cooking foods with high and sugar content. Follow manufacturer's directions.
Silicone containers	YES* (Cannot use the grill function with the water grill) Use a silicon container capable of withstanding temperatures more than 30°C higher than the set oven temperature. The temperature near the steam and hot air outlet is higher than the set temperature, and this can deform the container depending on its shape.	YES	YES Silicone containers heat-resistant temp. over 140°C
Paper Towels, Paper Plates	NO	NO	YES Paper towels: To cover for reheating and cooking. Do not use recycled paper towels which may contain metal filings. Paper plates: For reheating.
Containers made of synthetic material	NO They could melt at high temperature.	NO	NO
Baking paper	YES Do not touch the oven wall as it may be burnt. Keep the heat-resistant temp.	YES	NO
Roasting Bags	YES Roasting bags should only be used with Convection Oven.	NO	YES Follow manufacturer's directions.
Silver Dishes and Cooking Utensils or Containers that might rust inside the oven.	NO	NO	NO
Rack, Baking Tray	YES	YES	NO

# COOKING GUIDES

## Cooking Advices

1. Use ventilation when cooking, as cooking produces a lot of heat and steam.
2. Avoid as much as possible opening and closing the door when cooking. Allowing heat and steam to escape reduces cooking performance.
  - Check cooking conditions immediately after cooking is completed.
  - When opening the door during automatic cooking, refer to the Manual Cooking section of the online cookbook and cook manually.
3. When preparing a recipe from a common cookbook with a gas oven or another electric oven, cook while monitoring its progress. Refer to a similar recipe in the online cookbook and cook while monitoring its progress. Differences in oven cavity size, structure, and other features, however, may result in unsatisfactory cooking results despite using the cooking instructions given in commercial cookbooks or other recipe sources.

### For Cooking with Water

#### Use room temperature water suitable for drinking (filtered)

Slowly carry the baking tray while keeping it level: to avoid spilling meat juices, oils, hot water, or other liquids it may contain.

### For Convection/Grill

Once the dish is ready remove it from the oven.

- This prevents overcooking due to exposure to residual heat.
- When cooking with water, the dish may get wet due to a drop in temperature that cause vapor to condensate.

### For Automatic Cooking

When repeating cooking, use the results control while monitoring cooking.

Cavity or cooking accessories that are hot may result in overcooking and unsatisfactory results.

Use the indicated recipe ingredients and quantities, as they are compatible with this oven.

### Special Notes and Warning for Microwave

	DO	DON'T
Eggs, fruits, nuts, seeds, vegetables, sausages and oysters	<ul style="list-style-type: none"> <li>* Puncture egg yolks and whites and oysters before cooking to prevent "explosion"</li> <li>* Pierce skins of potatoes, apples, squash, hot dogs, sausages and oysters so that steam escapes.</li> </ul>	<ul style="list-style-type: none"> <li>* Cook eggs in shells. This prevents "explosion," which may damage the oven or injure yourself.</li> <li>* Cook hard / soft boiled eggs.</li> <li>* Overcook oysters.</li> <li>* Dry nuts or seeds in shells.</li> </ul>
Popcorn	<ul style="list-style-type: none"> <li>* Use specially bagged popcorn for the microwave oven.</li> <li>* Listen while popping corn for the popping to slow to 1-2 seconds.</li> </ul>	<ul style="list-style-type: none"> <li>* Pop popcorn in regular brown bags or glass bowls.</li> <li>* Exceed maximum time on popcorn package.</li> </ul>
Baby food	<ul style="list-style-type: none"> <li>* Transfer baby food to small dish and heat carefully, stirring often. Check for suitable temperature to prevent burns.</li> <li>* Remove the screw cap and teat before warming baby bottles. After warming shake thoroughly. Check for suitable temperature.</li> </ul>	<ul style="list-style-type: none"> <li>* Heat disposable bottles.</li> <li>* Overheat baby bottles.</li> <li>* Heat bottles with nipples on.</li> <li>* Heat baby food in original jars.</li> </ul>
General	<ul style="list-style-type: none"> <li>* Food with filling should be cut after heating, to release steam and avoid burns.</li> <li>* Use a deep bowl when cooking liquids or cereals to prevent boiling over.</li> <li>* When cooking small amounts of finely cut roots and the like, always soak them in an adequate amount of water. Cooking small amounts of less than 100g can cause accidents due to sparks, burnt food, and combustion.</li> </ul>	<ul style="list-style-type: none"> <li>* Heat or cook in closed glass jars or airtight containers.</li> <li>* Deep fat fry.</li> <li>* Heat or dry wood, herbs, wet papers, clothes or flowers.</li> <li>* Operate the oven without a load (i.e. an absorbing material such as food or water) in the oven cavity.</li> </ul>
Liquids (Beverages)	<ul style="list-style-type: none"> <li>* For boiling or cooking liquids see IMPORTANT SAFETY INSTRUCTIONS on page E-1-2 to prevent explosion and delayed eruptive boiling.</li> </ul>	<ul style="list-style-type: none"> <li>* Heat for longer than recommended time.</li> </ul>
Canned foods "Boil-in-the-bag" food	<ul style="list-style-type: none"> <li>* Put bagged and canned food in a container before cooking. Cooking food in aluminum and other metal containers can cause damage due to sparks. Bagged and canned food can be cooked by [17] Steam High.</li> </ul>	<ul style="list-style-type: none"> <li>* Heat or cook food while in cans or bags.</li> </ul>
Sausage rolls, Pies, Christmas pudding	<ul style="list-style-type: none"> <li>* Cook for the recommended time. (These foods have high sugar and / or fat contents)</li> </ul>	<ul style="list-style-type: none"> <li>* Overcook as they may catch fire.</li> </ul>



# AUTOMATIC COOKING CHART

## Sensor Reheat Menu Guide

### Cooking Mode: Microwave

Place the food in the centre of the oven floor.

Menu Name	Weight Range	Tips
Rice (initial temp 8-20°C)	1- 4 serves (1 serve: 150 g)	<ul style="list-style-type: none"> <li>• When reheating 1 serve, select LESS (▼) after pressing <b>START</b>.</li> <li>• When reheating the hard texture rice, sprinkle water.</li> </ul>
Frozen Rice (initial temp -18°C)	1- 2 serves (1 serve: 100 - 150 g)	<ul style="list-style-type: none"> <li>• Use the flat frozen rice of 2-3 cm thick covered with plastic wrap.</li> <li>• Place food on a plate.</li> <li>• Select LESS (▼) after pressing <b>START</b>.</li> </ul> 
Chinese Steamed Dumplings initial temp 8-20°C)	5 - 12 pieces (up to 160 g)	<ul style="list-style-type: none"> <li>• Sprinkle water to the food.</li> <li>• Cover with plastic wrap.</li> <li>• Select LESS (▼) after pressing <b>START</b>.</li> </ul>
Hamberg initial temp 8-20°C)	1 - 4 pieces (1 piece: 90 g)	<ul style="list-style-type: none"> <li>• Do not cover.</li> <li>• Select MORE (▲) after pressing <b>START</b>.</li> </ul>
Tempura (initial temp 8-20°C)	0.1 - 0.4 kg	<ul style="list-style-type: none"> <li>• Put kitchen paper on the plate, then put food in the single layer on it.</li> <li>• Do not cover.</li> </ul>
Grilled Chicken Skewers (initial temp 8-20°C)	2 - 6 skewers (up to 150 g)	<ul style="list-style-type: none"> <li>• Do not cover.</li> </ul>
Pilaf (initial temp 8-20°C)	0.1 - 0.4 kg	<ul style="list-style-type: none"> <li>• Do not cover.</li> <li>• After cooking, stir.</li> </ul>
Fried Noodles (initial temp 8-20°C)	0.1 - 0.2 kg	<ul style="list-style-type: none"> <li>• Add a little butter or oil if the food is dry before cooking.</li> <li>• Do not cover.</li> <li>• After cooking, stir.</li> </ul>
Curry (initial temp 8-20°C)	0.2 - 0.4 kg	<ul style="list-style-type: none"> <li>• Cover with plastic wrap.</li> <li>• Select LESS (▼) after pressing <b>START</b>.</li> </ul>
(initial temp -18°C)	0.2 - 0.4 kg	<ul style="list-style-type: none"> <li>• Use shallow dish.</li> <li>• Cover with plastic wrap.</li> </ul>
Simmered food (initial temp 8-20°C)	0.1 - 0.4 kg	<ul style="list-style-type: none"> <li>• Do not cover except for simmered fish.</li> </ul>
Miso Soup (initial temp 8-20°C)	1- 2 cups (1 cup: 150 mL)	<ul style="list-style-type: none"> <li>• Do not cover.</li> <li>• Select MORE (▲) after pressing <b>START</b>.</li> </ul>

# AUTOMATIC COOKING CHART

## Defrost Menu Guide

**Cooking Mode:** Microwave with Steam

Menu Name	Weight Range	Water Level	Tips
Chunk of Meat (initial temp -18°C)	0.1 - 0.5 kg	1 or more	<ul style="list-style-type: none"> <li>Remove from original wrapper.</li> <li>Put the plastic wrap in the centre of the oven floor, then place the food on it.</li> <li>Do not cover.</li> <li>Select MORE (▲) after pressing <b>START</b>.</li> </ul>
Sliced Meat Boneless Chicken (thigh/breast) Minced meat (initial temp -18°C)	0.1 - 0.5 kg	1 or more	<ul style="list-style-type: none"> <li>Remove from original wrapper.</li> <li>Put the plastic wrap in the centre of the oven floor, then place the food on it.</li> <li>Do not cover.</li> <li>For 100 g, select LESS (▼) after pressing <b>START</b>.</li> </ul>
Fish Fillet Squids, Prawns (initial temp -18°C)	0.1 - 0.5 kg	1 or more	<ul style="list-style-type: none"> <li>Remove from original wrapper. Shield thin end with foil.</li> <li>Put the plastic wrap in the centre of the oven floor, then place the food on it.</li> <li>Do not cover.</li> <li>For Defrost, select LESS (▼) after pressing <b>START</b>.</li> <li>For Defrost Low with 400 g or more, select MORE (▲) after pressing <b>START</b>.</li> </ul>

Foods not listed in the Guide can be defrosted manually using 200W power level setting.





**NOTE:**

After the cooking with Convection or Oven function, the oven floor will be too hot. Defrost food after the oven has completely cool, because the plastic wrap may melt on the hot oven floor.

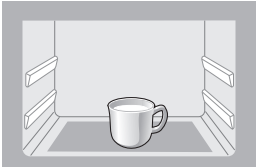

## Beverage Menu Guide





**Cooking Mode:** Microwave

Menu Name	Quantity	Tips
Milk (initial temp 8°C)	1 - 4 cups (1 cup: 200 mL)	<ul style="list-style-type: none"> <li>Use wide-mouthed container.</li> <li>Do not cover.</li> <li>Stir the liquid before cooking.</li> <li>Place the cup in the centre of the oven floor.</li> <li>After cooking, stir.</li> </ul>
Coffee (initial temp 20°C)	1 - 4 cups (1 cup: 150 mL)	   

# AUTOMATIC COOKING CHART

## Auto Sensor Cook (ALL IN ONE) Menu Guide

- Refer to the online cookbook, ensure the suitable menus and follow to SHARP instructions.

Menu Name	Weight Range	Procedure	Cooking Mode	Water Level
1. Grill 	Up to 1 kg	<b>Place food on rack in baking tray and then cook.</b> <ul style="list-style-type: none"> <li>• Use to salt grill or sauce broil meat and fish.</li> <li>• Oil-free cooking for deep fried is available.</li> <li>• Prepare a quick meal by adding your favorite vegetables with meat/fish and cooking them at the same time.</li> <li>• See the online cookbook.</li> </ul>	Water Oven	1 or more
2. Bake 	Up to 1 kg	<b>Place food on baking tray and then cook.</b> <ul style="list-style-type: none"> <li>• Grill fish, gratin, and other familiar dishes.</li> <li>• Prepare a more balanced meal by adding your favorite vegetables and cooking them at the same time.</li> <li>• See the online cookbook.</li> </ul>	Water Oven	1 or more
3. Stir Fry 	Up to 1 kg	<b>Spread out on baking tray and cook.</b> <ul style="list-style-type: none"> <li>• You can cook stir-fried using the baking tray as a frying pan.</li> <li>• See the online cookbook.</li> </ul>	Water Oven	1 or more
4. Steam 	Up to 0.8 kg	<b>Steam vegetables, meat, fish, eggs, and store-bought foods.</b> <ul style="list-style-type: none"> <li>• Place food on rack in baking tray and then cook.</li> <li>• Steam chicken, vegetables, and the like.</li> <li>• Add variety with dressings and sauces.</li> <li>• See the online cookbook.</li> </ul>	Steam	2 (MAX)

# AUTOMATIC COOKING CHART

## Auto Menu Guide

- Refer to the online cookbook, ensure the suitable menus and follow to SHARP instructions.

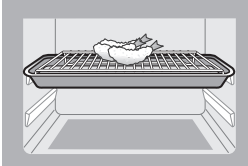
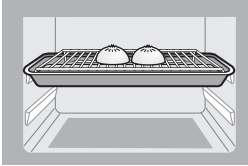
Menu Name	Weight Range	Procedure	Cooking Mode
1. Crispy Reheat		<p><b>Water Level: 1 or more</b> <b>Food Position: Upper</b></p> 	Water Oven
Tempura (initial temp 8 -20°C)	100 - 600 g	<ul style="list-style-type: none"> <li>• Put food on rack in baking tray, uncovered.</li> <li>• When reheating 400 g or more, select MORE (▲) after pressing <b>START</b>.</li> </ul>	
Meat Cutlet (initial temp 8 -20°C)	100 - 600 g	<ul style="list-style-type: none"> <li>• Put food on rack in baking tray, uncovered.</li> <li>• Select LESS (▼) after pressing <b>START</b>.</li> </ul>	
French Fries (initial temp 8 -20°C)	100 - 200 g		
Fried Chicken on the Bone (initial temp 8 -20°C)	100 - 400 g		
Grilled Fish Yakitori (Grilled Chicken Skewers) (initial temp 8 -20°C)	100 - 300 g		
Hamburg (initial temp -18°C, 8 - 20°C)	1 - 4 pieces (1 piece : approx. 90 g)	<ul style="list-style-type: none"> <li>• Put food on rack in baking tray, uncovered.</li> <li>• For food at 8 -20°C, select LESS (▼) after pressing <b>START</b>.</li> </ul>	
2. Steam Reheat		<p><b>Water Level: 2 (MAX)</b> <b>Food Position: Upper</b></p> 	Steam
Steamed Buns (initial temp -18°C, 8 - 20°C)	1 - 4 pieces (1 piece : 70 - 120 g)	<ul style="list-style-type: none"> <li>• Put food on rack in baking tray, uncovered.</li> <li>• When reheating bigger bun (120 g), select MORE (▲) after pressing <b>START</b>.</li> </ul>	
Chinese Steamed Dumplings (initial temp -18°C, 8 - 20°C)	5 - 12 pieces (up to 160 g)	<ul style="list-style-type: none"> <li>• Put food on rack in baking tray, uncovered.</li> <li>• Select LESS (▼) after pressing <b>START</b>.</li> </ul>	
Steamed Rice (initial temp 20°C)	100 - 600 g	<ul style="list-style-type: none"> <li>• Put food in rice bowl.</li> <li>• Place the bowl on baking tray, uncovered.</li> <li>• When reheating 150 g or less, select LESS (▼) after pressing <b>START</b>.</li> </ul>	
Canned foods (initial temp 20°C)	1 - 2 cans (1 can : 80 - 100 g)	<ul style="list-style-type: none"> <li>• Open the lid of the can.*</li> <li>• Place on the rack in baking tray</li> <li>• Select LESS (▼) after pressing <b>START</b>.</li> </ul> <p>*Although you can cook canned foods without opening the lid, you should open it before cooking to prevent burns.</p>	

# AUTOMATIC COOKING CHART

## Auto Menu Guide

- Refer to the online cookbook, ensure the suitable menus and follow to SHARP instructions.

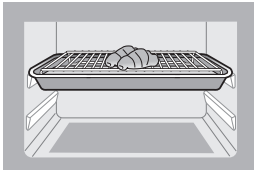
Menu Name	Weight Range	Procedure	Cooking Mode
3. Reheat Bread		<p><b>Water Level:</b> 1 or more <b>Food Position:</b> Upper</p> 	Water Oven
3-1. Dinner Roll (initial temp -18°C, 8 - 20°C)	30 - 240 g (1 - 8 pieces)	<ul style="list-style-type: none"> <li>Put food on rack in baking tray, uncovered.</li> <li>When reheating 90 g or less, select LESS (▼) after pressing <b>START</b>.</li> <li>When reheating 2 pieces of Savoury Buns (200 g), select MORE (▲) after pressing <b>START</b>.</li> </ul>	
3-1. Pizza (initial temp -18°C, 8 - 20°C)	100 - 400 g (1 - 4 slices)	<ul style="list-style-type: none"> <li>Put food on rack in baking tray, uncovered.</li> <li>For 300 g or more, select MORE (▲) after pressing <b>START</b>.</li> </ul>	
3-2. Baguette (initial temp -18°C, 8 - 20°C)	30 - 240 g (1 - 8 slices)	<ul style="list-style-type: none"> <li>Use baguettes sliced less than 4 cm in thick.</li> <li>Put food on rack in baking tray, uncovered.</li> <li>When reheating 90 g or less, select LESS (▼) after pressing <b>START</b>.</li> <li>When reheating 2 pieces of Savoury Buns (200 g), select MORE (▲) after pressing <b>START</b>.</li> </ul>	
3-3. Croissant/Pie (initial temp -18°C, 8 - 20°C)	40 - 240 g (1 - 6 pieces)	<ul style="list-style-type: none"> <li>Put food on rack in baking tray, uncovered.</li> <li>When reheating 80 g or less, select LESS (▼) after pressing <b>START</b>.</li> <li>When reheating 2 pieces of Savoury Buns (200 g), select MORE (▲) after pressing <b>START</b>.</li> </ul>	

# AUTOMATIC COOKING CHART

## Auto Menu Guide

- Refer to the online cookbook, ensure the suitable menus and follow to SHARP instructions.

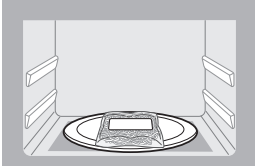
Menu Name	Weight Range	Procedure	Cooking Mode
4. Reheat Frozen Food		Use mainly for reheating commercial Frozen Meal (microwave-safe) for one person.	Microwave
Spaghetti (initial temp -18°C)	1 serve (180 - 360 g)	<ul style="list-style-type: none"> <li>• Prepare food as mentioned on the package.</li> <li>• Place the food in the centre of the oven floor.</li> <li>• After cooking, stir.</li> </ul>	
Fried Noodles (initial temp -18°C)	1 serve (200 - 300 g)	<ul style="list-style-type: none"> <li>• Prepare food as mentioned on the package.</li> <li>• Place the food in the centre of the oven floor.</li> <li>• After cooking, stir.</li> </ul>	
Fried Rice (initial temp -18°C)	200 - 450 g	<ul style="list-style-type: none"> <li>• Prepare food as mentioned on the package.</li> <li>• Break up the food before cooking.</li> <li>• Cover with plastic wrap.</li> <li>• Place the food in the centre of the oven floor.</li> <li>• After cooking, stir.</li> </ul>	
Chinese Steamed Dumplings (initial temp -18°C)	5 - 12 pieces (up to 160 g)	<ul style="list-style-type: none"> <li>• Prepare food as mentioned on the package.</li> <li>• Sprinkle water to the food.</li> <li>• Cover with plastic wrap.</li> <li>• Place the food in the centre of the oven floor.</li> </ul> <p>Tip: You can also reheat on menu No. 2 (Steam Reheat) for moist texture.</p>	
Vegetable; Taro/Pumpkin (initial temp -18°C)	100 - 400 g	<ul style="list-style-type: none"> <li>• Prepare food as mentioned on the package.</li> <li>• Cover with plastic wrap.</li> <li>• Place the food in the centre of the oven floor.</li> </ul>	

# AUTOMATIC COOKING CHART

## Auto Menu Guide

- Refer to the online cookbook, ensure the suitable menus and follow to SHARP instructions.

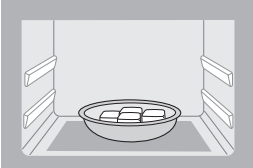
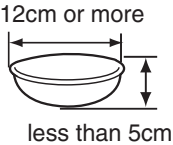
Menu Name	Weight Range	Procedure	Cooking Mode
5. Reheat as Temperature	1 - 2 serves (up to 200 g)	<p>Use to soften butter or reheat soup by setting desired temperature.</p>  <p><b>Temperature Range:</b> -10°C, 20 - 90°C (5°C per step)</p> <ul style="list-style-type: none"> <li>• Do not cover.</li> <li>• When using containers, put the food in one container. The recommended container size: Width: 12cm or more Height: less than 5 cm</li> <li>• Place the food in the centre of the oven centrev.</li> </ul>  <p><b>NOTES:</b></p> <ul style="list-style-type: none"> <li>• Do not reheat any beverages with this function. Reheat with <b>BEVERAGE</b>. See page E-11.</li> <li>• Do not reheat buns contained chocolate or cream.</li> </ul> <div style="border: 1px solid black; padding: 5px; margin-top: 10px;"> <p>Recommended Temperature</p> <p>Soup: 80 - 90°C</p> <p>Rice: 60 - 70°C</p> <p>Savoury Buns: 50 - 60°C</p> <p>Rice Ball: 40 - 50°C</p> <p>Butter: 20°C</p> <p>Ice Cream: -10°C</p> </div>	Microwave
6. Grilled Chicken	2 or 4 serves	• See the online cookbook.	Water Grill
7. Deep Fried Chicken	2 or 4 serves	• See the online cookbook.	Water Oven
8. Grilled Fish	2 or 4 serves	• See the online cookbook.	Water Grill

# AUTOMATIC COOKING CHART

## Auto Menu Guide

- Refer to the online cookbook, ensure the suitable menus and follow to SHARP instructions.

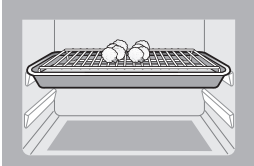
Menu Name	Weight Range	Procedure	Cooking Mode
9. Steamed Vegetables Spinach Asparagus Broccoli Daikon Radish Pumpkin Carrot	0.1 - 0.4 kg	<p><b>Water Level: 2 (MAX)</b> <b>Food Position: Upper</b></p>  <ul style="list-style-type: none"> <li>• Wash vegetables, then remove excess water.</li> <li>• Cut and trim the vegetables into florets, shreds or strips.</li> <li>• Put vegetables on rack in baking tray, uncovered.</li> <li>• Put the baking rack on the upper position in the oven.</li> </ul> <p>For Spinach, Asparagus: Select LESS (▼) after pressing <b>START</b>.</p> <p>For Radish, Pumpkin, Carrot: Select MORE (▲) after pressing <b>START</b>.</p>	Steam
10. Baked Sweet Potato	1 - 4 pieces (1 piece: 250 g)	<ul style="list-style-type: none"> <li>• See the online cookbook.</li> </ul>	Water Oven
11. Toast	2 or 4 slices	<ul style="list-style-type: none"> <li>• See the online cookbook.</li> </ul>	Water Oven
12. Breakfast Set	2 or 4 serves	<ul style="list-style-type: none"> <li>• See the online cookbook.</li> </ul>	Water Oven
13. Sponge Cake	1 - 2 layers	<ul style="list-style-type: none"> <li>• See the online cookbook.</li> </ul>	Water Oven
14. Cream Puff	1 - 2 layers (1 layer: 12 pieces)	<ul style="list-style-type: none"> <li>• See the online cookbook.</li> </ul>	Water Oven
15. Dried Food 15-1. Dried Fruit (soft) 15-2. Dried Chips 15-3. Snacks	2 layers	<ul style="list-style-type: none"> <li>• See the online cookbook.</li> </ul>	Water Oven





## 選項號碼

The following options are selected by turning the Knob. Each option number will be shown in the display.

自動菜單		自選烹調	保養
1 香脆加熱	9 蒸蔬菜	16 燒烤	21 除菌
2 純蒸加熱	10 焗蕃薯	17 高溫蒸氣	22 排水
3 麵包加熱	11 多士	18 低溫蒸氣	23 蒸氣清潔
-1 捲/薄餅	12 早餐套餐	19 蒸氣發酵	24 除垢
-2 法國麵包	13 海綿蛋糕	20 發酵	25 清潔水波爐 (首次使用)
-3 牛角包/批	14 泡芙		
4 冷凍食品加熱	15 風乾食物		
5 加熱溫度	-1 乾果 (軟身)		
6 烤雞	-2 脆片		
7 炸雞	-3 小食		
8 烤魚			

## OPTION NUMBER

The following options are selected by turning the Knob. Each option number will be shown in the display.

AUTO MENU		MANUAL COOKING	MAINTENANCE
1 Crispy Reheat	9 Steamed Vegetables	16 Grill	21 Sterilization
2 Steam Reheat	10 Baked Sweet Potato	17 Steam High	22 Drain Water
3 Reheat Bread	11 Toast	18 Steam Low	23 Steam Clean
-1 Roll/Pizza	12 Breakfast Set	19 Steam Proof	24 Descale
-2 Baguette	13 Sponge Cake	20 Proof	25 Clean Oven (First Use)
-3 Croissant/Pie	14 Cream Puff		
4 Reheat Frozen Food	15 Dried Food		
5 Reheat as Temperature	-1 Dried Fruit (Soft)		
6 Grilled Chicken	-2 Dried Chips		
7 Deep Fried Chicken	-3 Snacks		
8 Grilled Fish			